

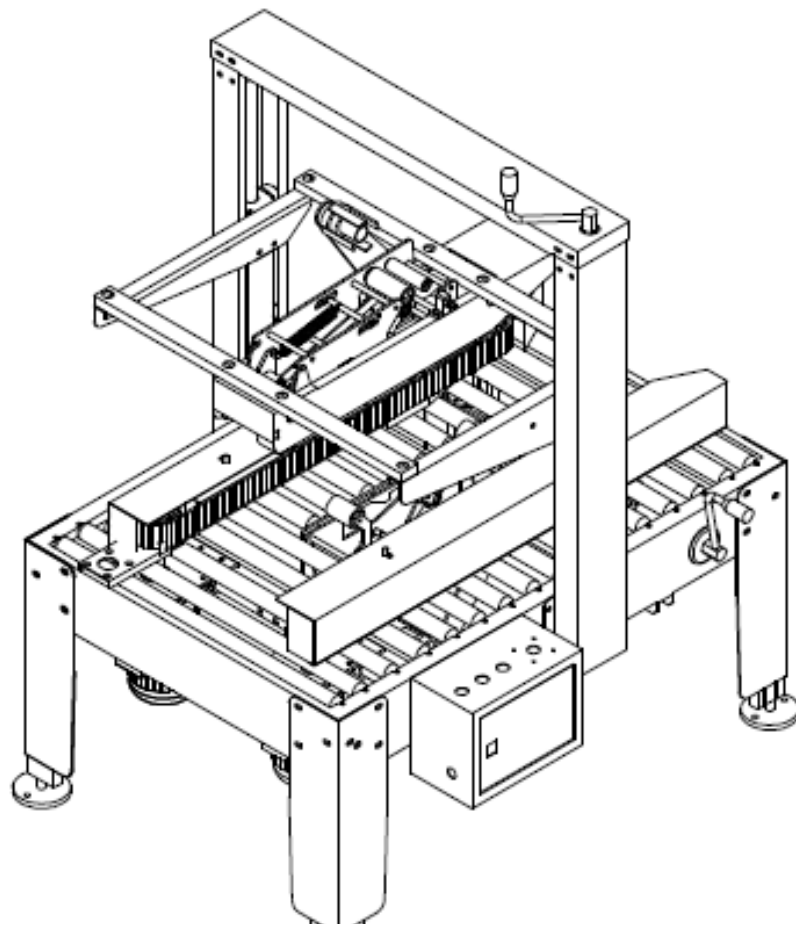

# Pacmasta<sup>®</sup>

## PMCS-100

Use, Maintenance And Spare Parts Handbook



**02 9452-3566**

**[sales@getpacked.com.au](mailto:sales@getpacked.com.au)**

Rev	Data



**The machine should be exclusively operated by previously trained personnel.**

### **General safety regulations**

Before using the machine or carrying out maintenance operation read the following instructions very carefully:

#### **Before**

- Carefully read the instructions about the machine;
- Check all the safety guards on the machine and immediately replace any worn or broken parts with original spares;
- Make sure that no tools or other objects have been left lying on the machine and that the machine itself is perfectly clean;
- Read the Use, Maintenance and Spare Parts Handbook very carefully;
- Read all the labels and plates applied to the machine.

#### **During**

- Do not wear clothing that could get tangled up in the moving parts of the machine;
- Do not carry on maintenance operation barefoot;
- Do not put the hands or any kind of object inside the field of operation of the machine;
- Do not load the machine with boxes heavier than those recommended by the manufacturer.

#### **After**

- Turn the master switch to OFF to stop the whole machine.



**The machine should be exclusively operated by previously trained personnel.**

### **Safety regulations for maintenance**

- Follow the maintenance regulations given in this handbook;
- Never repair, lubricate or adjust the machine while it is in movement;
- Always turn off the power supply before opening the safety guards;
- Do not use any parts other than the originals without the written permission of YOUNGSUN;
- Always use original spare parts.

### **Useful hints**

- Always use appropriate electrical connection systems;
- Do not remove or cover up the labels and plates on the machine;
- Consult the Use and Maintenance Handbook whenever necessary.

## INDEX

<b>PART 1. DETAIL INTRODUCTION</b>		
1.1	Using machine affirms	Page 06
1.2	Function	Page 06
1.3	Tape	Page 06
1.4	Case size	Page 07
1.5	Machine size	Page 08
1.6	technical parameter	Page 08

<b>PART 2. PREPARATION BEFORE RUNNING</b>		
2.1	Pre-process	Page 09
2.2	Nameplate	Page 11
2.3	Moving and positioning	Page 12
2.4	Working position	Page 13
2.5	inspection component and Set	Page 14
2.6	Working dedendum	Page 15
2.7	Connectenate roller	Page 16
2.8	Install botton plane head	Page 19
2.9	Install top plane head	Page 20
2.10	Kinds of plane head	Page 21
2.11	Connect power,electrical machine and use	Page 22
2.12	Debugging	Page 24

<b>PART 3. SETTING</b>		
3.1	Pretreatment	Page 25
3.2	Setting top plane head	Page 25
3.3	Setting raceway cutout	Page 26
3.4	Setting sidewheel	Page 26
3.5	Work cycle	Page 27
3.6	Warning for Trouble shooting	Page 27
3.7	Step for servicing	Page 27
3.8	Possible troubles and processing method	Page 28
3.9	Warning sign	Page 29
3.10	Possible troubles menu	Page 30

<b>PART 4. SERVICE</b>		
4.1	Daily maintenance and provision	Page 34
4.2	Replace raceway girdle	Page 34
4.3	Wearing parts recommended list	Page 35
4.4	Projects for regularmaintain and cleaning	Page 35

<b>PART 5. CHART AND LIST FOR MAIN PARTS</b>		
5.1	Stander	Page 36
5.2	Upright post component (lifting gear)	Page 37
5.3	Parts of rollers	Page 39
5.4	Side Powerplant	Page 40
5.5	Plane head	Page 42
5.6	Cases Round up device	Page 44
5.7	Clock mechanism	Page 46

<b>PART 6. WIRING AND SCHEMATIC DIAGRAMS</b>		
6.1	Wiring and schematic diagrams	Page 58

## **PART 1: DETAIL INTRODUCTION**

### **1. Using machine affirms:**

#### **Operating the machine**

- The machine is developed for sealing cases, meanwhile it is allowed for for the purpose of using the sealing, please attention to the weight capacity in the specification.
- Please use the machine after every term is explicit .

#### **In the following cases, the machine does not allow to be used, such as:**

- The protective cover is not in the place.
- Transmission roller is not in the place
- Botton of the machine is instability.

#### **The machine is not allowed to use in Explosion hazards aire.**

#### **Notice:**

Here clearly indicate, do no to wear bracelets, watches, rings, bracelets, ties, belts, etc at work. The worker should limit the freedom of action to avoid harm to themselves.Operators' clothes must comply with safety requirements when they maintaining and operating

### **2. Function of the machine**

Manual folding case-lid, and then the machine automatically shut down both up and down sides of the box.

#### **Notice:**

Cartons must be located in the middle of the machine, sealing parts of top and botton.

### **3. Tape**

Plane head of machines have access to 48-72mm wide tape, it can be customized according to customer needs.

#### 4. Carton size:

(refer to chart 1-1)

#### Notice:

In order for the machine to good working, please consider the length and breadth and weight of cartons.

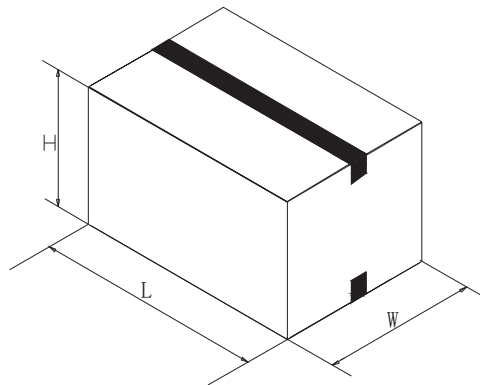

Chart 1-1

Native machine used in sealing size as follow, it can be customized according to customer needs:

Length: 150-∞mm; width: 120-480mm; height:120-480mm



5. Machine Size (refer to the chart following)

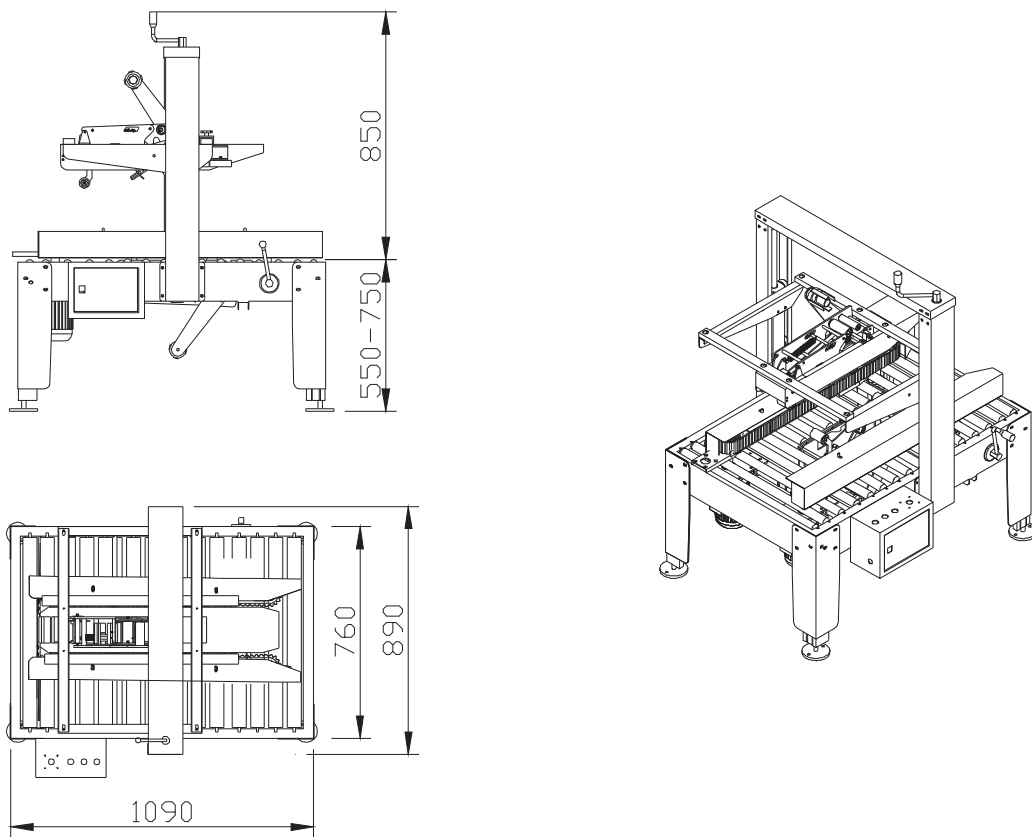

6.	Technical parameters	MH-FJ-1AW
	Power supply	1P, AC220V, 50Hz, 600W
	Sealing speed	19meter/minute
	Weight caacity	40kg
	Machine size	L1090×W890×H (table top add 850) mm
	Workingtable height	550-750mm (tunableness)
	Sealing tap	Kraft tap, BOPP tap
	Tape size	48-72mm
	Carton size	L 150-∞mm; W120-480mm; H 120-480mm
	Machine weight	100kg
	Nocise	≤75DB
	Condition	Humidity≤98%, temperature 0-40℃
	Lubrication	General application lubrication oil
	Performance	When carton size is changed, Artificial positioning adjust left and right、 up and down , automatic timely delivery,sealing top and botton at the same time, side belt drive.

## PART 2: PREPARATION BEFORE RUNNING

### 1. Pre-process

Please check after open of wooden box:

- Any parts fall off from machine or not?
- Get rid of binding substances around the machine
- Check whether model correct or not
- Spare parts and tools and Operation manual with declare of signs symbols
- Report to manufacturer of any damages caused by transportation

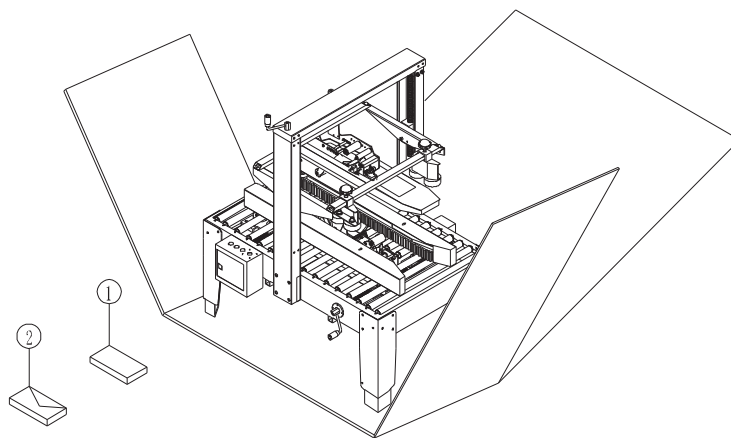

1. a operation manul

2. spare parts and tools

Some need yourself to install upright, the installation steps are as follows:

Stand the upright on end, than screw it down with screws. As shown in Chart 2-2 and 2-3

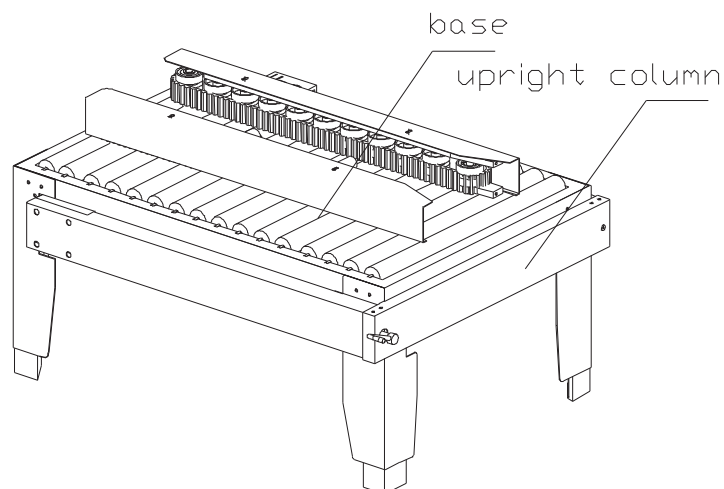

Chart 2-2

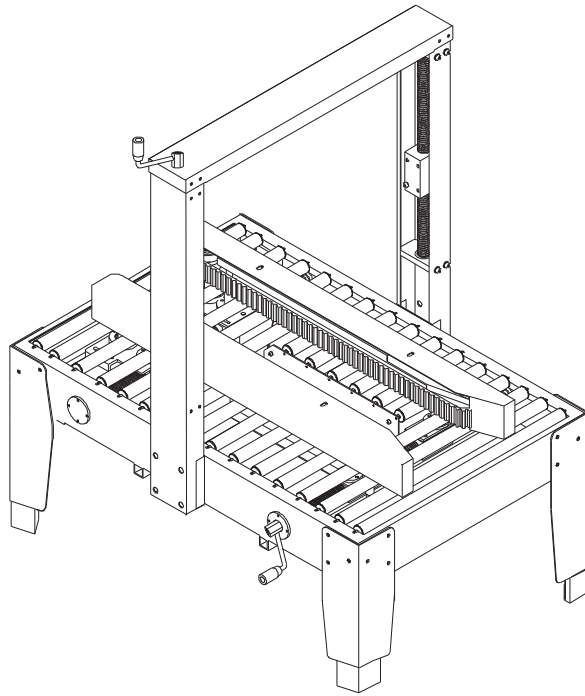

Chart 2-3

## 2. Nameplate

Please inform the supplier the order number and Modle of products for feedback  
(chart 2-4)



<b>Carton sealing machine</b>  	
Mode:MH-FJ- <u>1AW</u>	Specification: _____
Power:single-phase	Sealing speed: _____
AC <u>220</u> V, <u>50</u> Hz, <u>0.4</u> Kw	<u>19</u> m/min
Air pressure: _____	Delivery date: _____
_____ kg/cm <sup>2</sup>	_____
N.W.: <u>100</u> kg	Cade: _____

Chart 2-4

### 3. Moving and positioning

Fokelift forks the beam (chart 2-5) removes the cork base, because of there are clock mechanism and motor in the upper part of the machine. So pay attention to that :the machine must set up in the enough room ,space between left and right are 800 mm each at least. (chart 2-6)

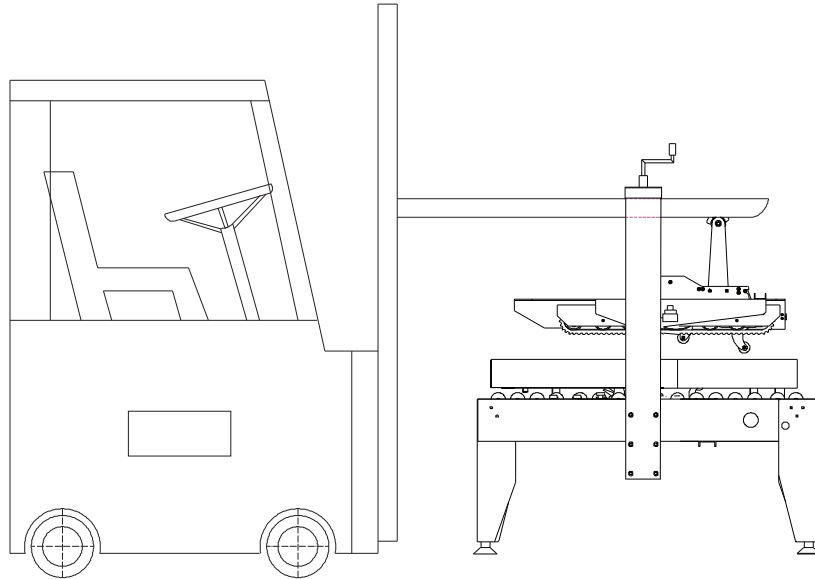

Chart 2-5

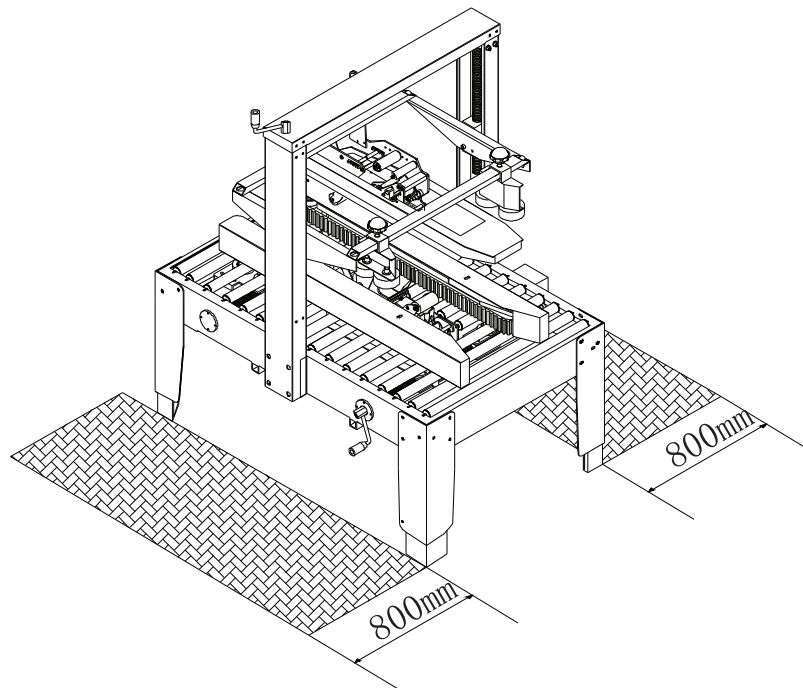

Chart 2-6

#### 4. Working position

When working ,the operator stand just right ahead away from the machine about 10cm(can operate the label object and the control panel freely will be ok). (Chart 2-7)

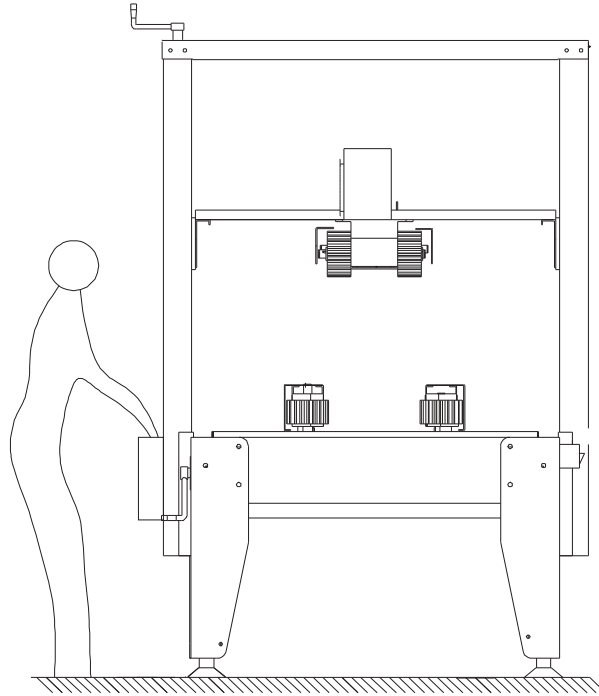
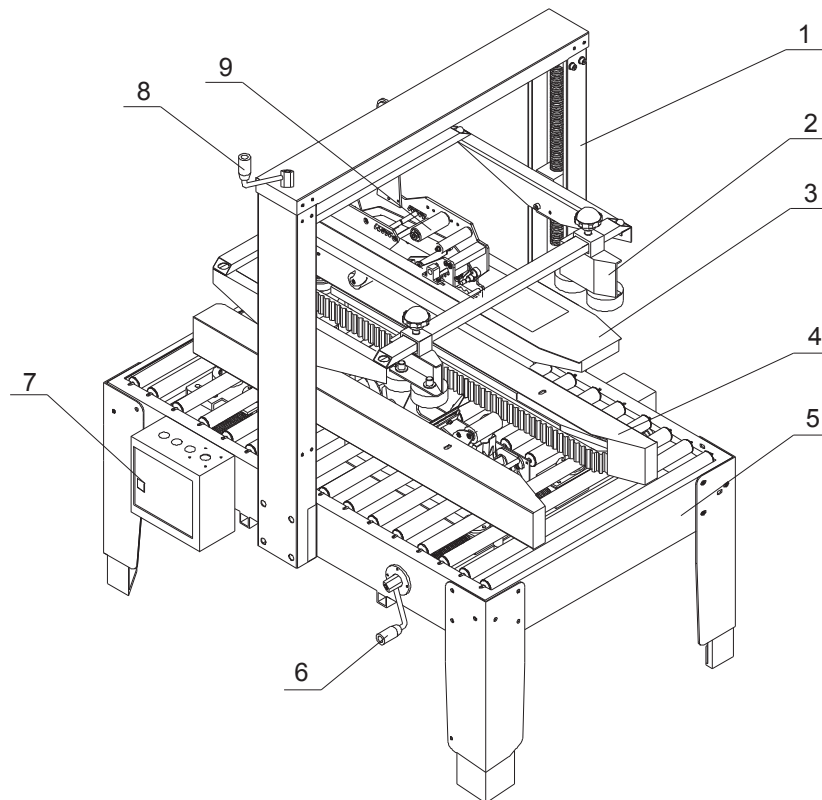

Chart 2-7

## 5. Inspection component and Set



- |                           |                               |
|---------------------------|-------------------------------|
| 1. Upright post component | 6. Handle of adjusting width  |
| 2. Holding box equipment  | 7. electrical box             |
| 3. Plane head             | 8. Handle of adjusting height |
| 4. Side-impetus equipment | 9. Clock mechanism            |
| 5. Base                   |                               |

## 6. working dedendum

Working dedendum of the machine is between 550-750mm (from rolling surface to ground surface) . Put the connection plate into the flex foot according to the direction of arrow in the Chart 2-9, the flex foot is able to adjusted the height up and down. reuse within hexagonal screw connect fixed block to connection plate that adjust the height of work bench.

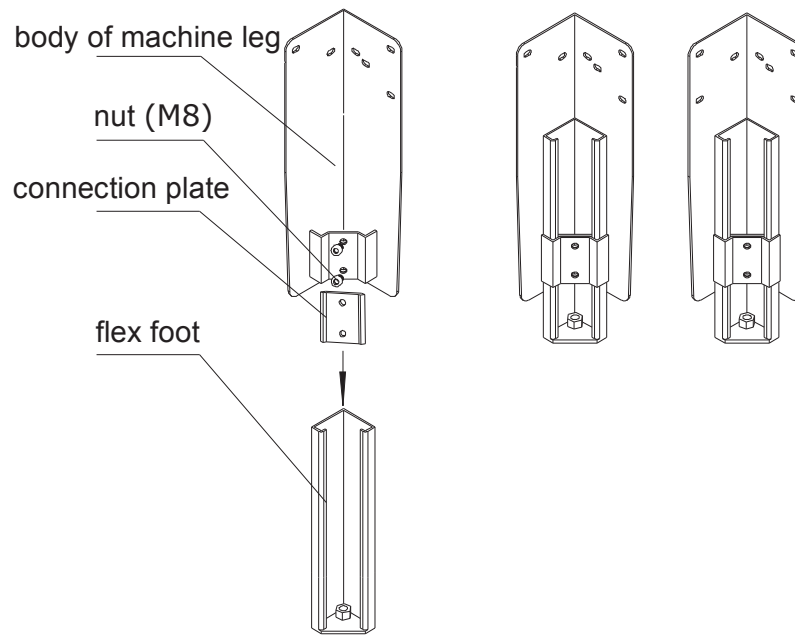

Chart 2-9

### Notice:

Please check that whether the length and width are just the same after over the aforementioned work.



## 7. Concatenate rollaway

The machine is able to connect to other rollaways (such as unpowered straight rollaways ect. It is used regard as work bench or feedway of pipelining) The rollaway that will put up the carton sealer directly. There are three main forms, refer to Chart 2-10, 2-11, 2-12 shown:

The installation rack for concatenate rollaway refer to the shown:

### The first species:

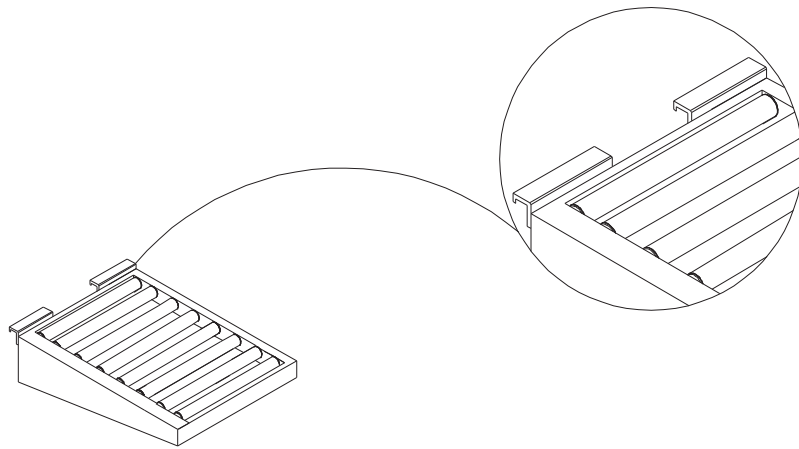

Chart 2-10

### The second species

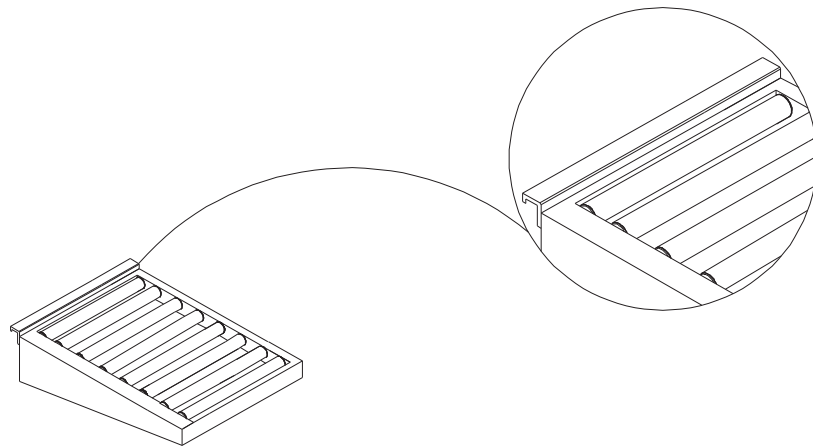

Chart 2-11

**The third species:**

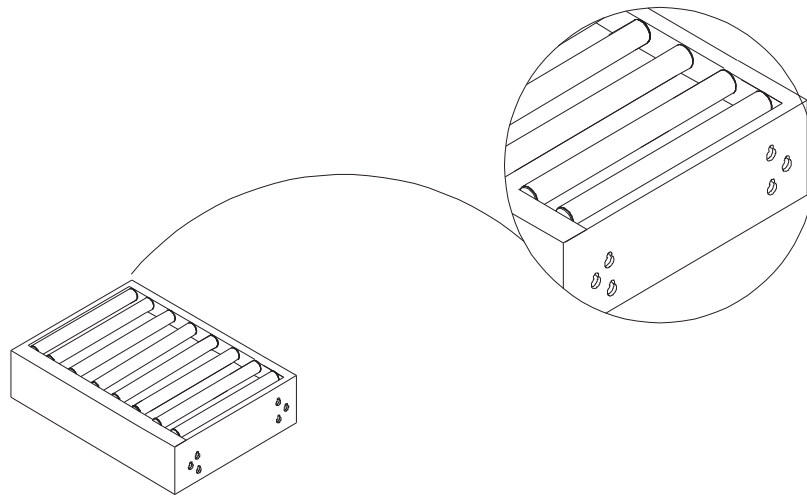

Chart 2-12

The rollaway put up the carton sealer refer to shown:

**The first species:**

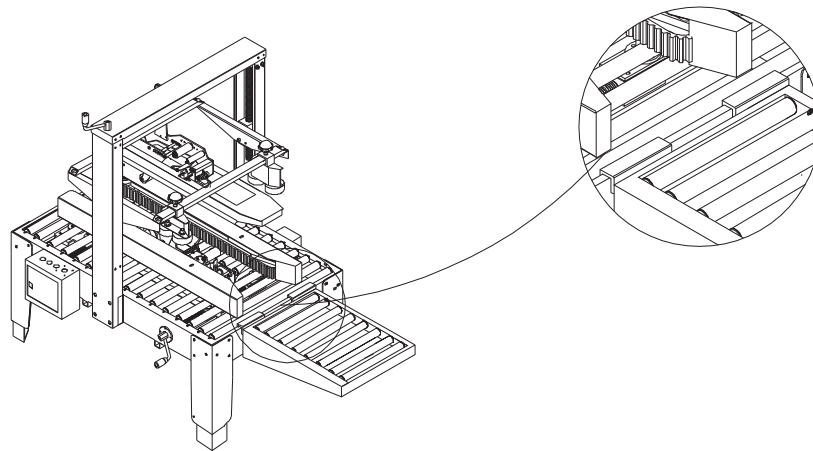

Chart 2-13

**The second species:**

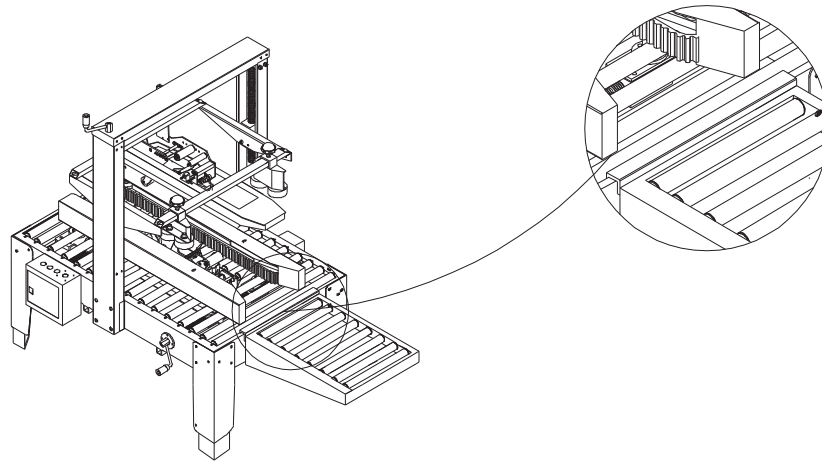

Chart 2-14

**The third species:**

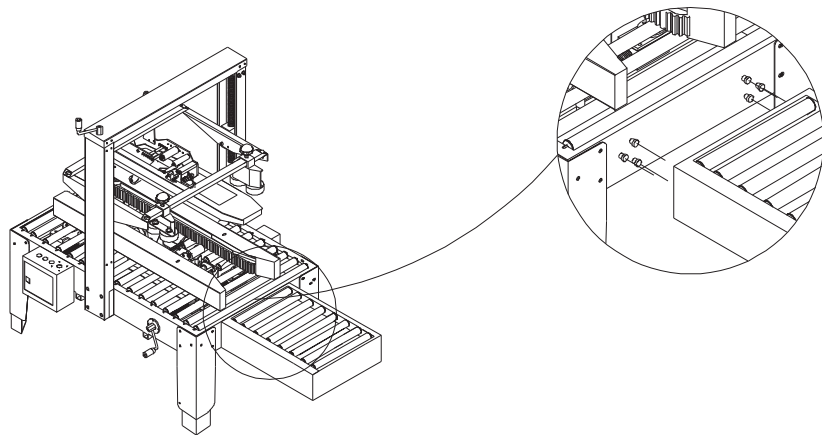

Chart 2-15

## 8. Install the plane head of bottom

Install the plane head has to get through correlation direct introductions ,provide for posterior work ,service and accessories. Using the specify open ended rollaway that accord with machine installed.Install the toward of plane head as shown Chart 2-16. Screw bolts joint up the half hole set 1 and the hole set 3 in Chart 2-16.Put the hole set 2 up the back shaft set 4 sufficiently.

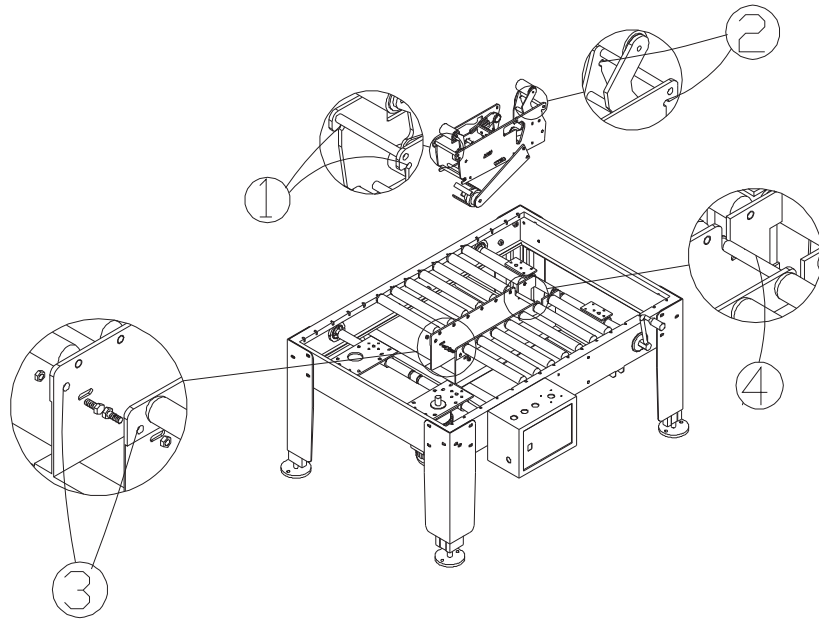

Chart 2-16

## 9. Install the plane head of upper part of carton sealer

After getting ready for the plane head of upper part of carton sealer, heave up tie bar set 4 in chart 2-17, put the plane head in as shown, let the tie bar go when the hole set 2 in chart 2-17 is arming at the tie bar, meanwhile, the half hole set 1 is just on the back shaft set 3 in chart 2-17 sufficiently.

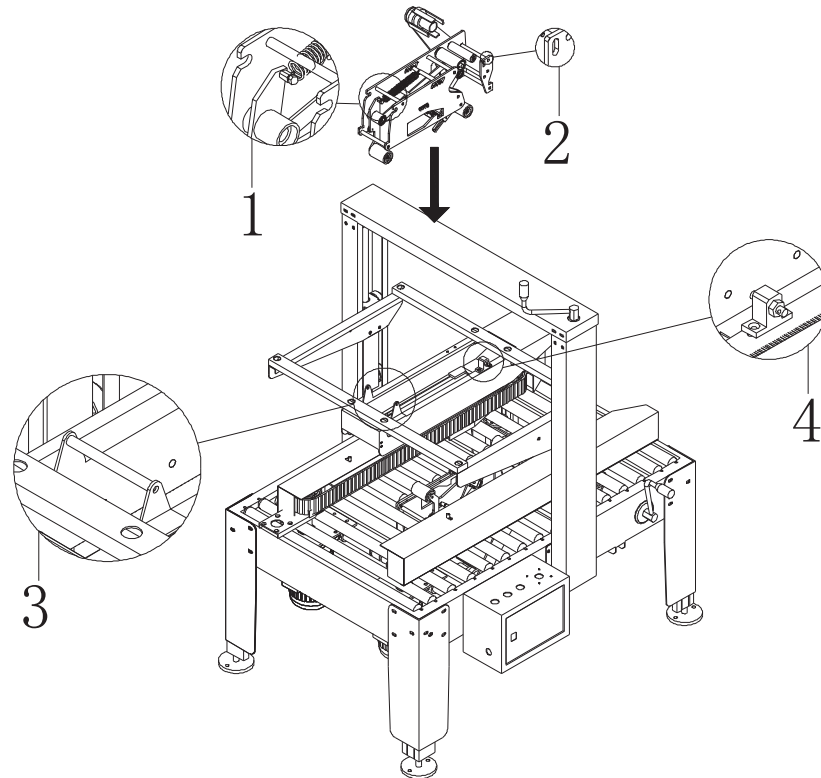
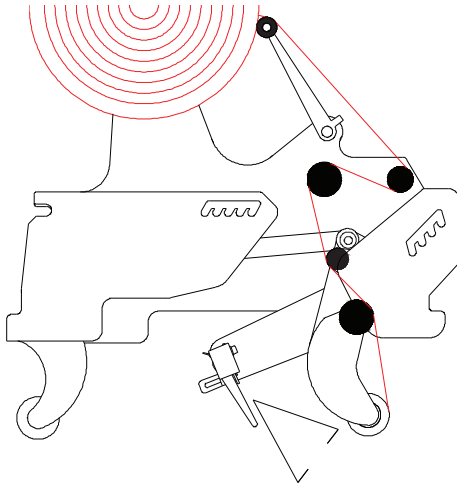
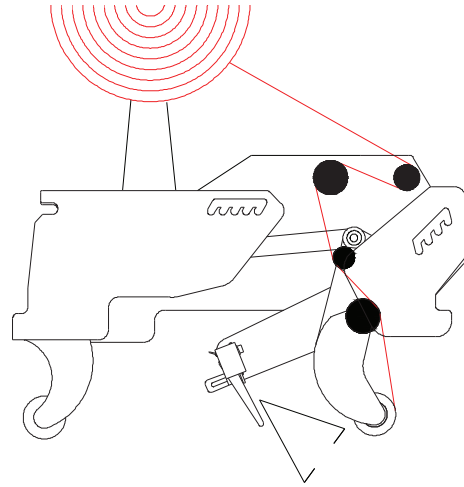

Chart 2-17

## 10. Kinds of plane head



TH-2



TH-1

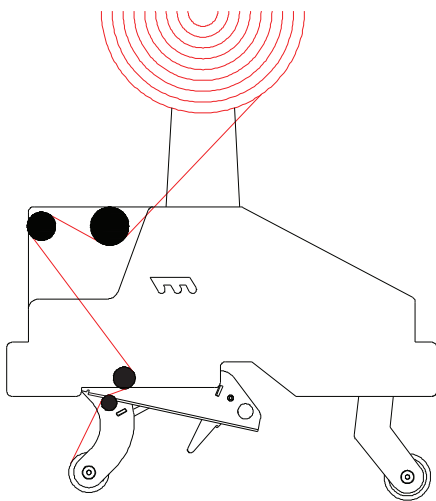

TH-4

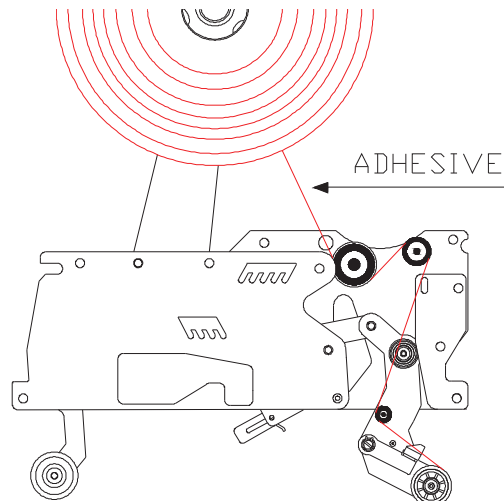

TH-5

Every kind of plane head is fit for any carton sealer. It is easy and faster to install.

## 11. Connect power、 electrical machine and go into service

### Notice:

Before connecting power, please check that whether the power on-off is closed, if there are other goods on the worktable or not first.

### Confirmation before using

- Please confirm the power supply for the machine.
- Check whether the fastener become less crowded or not .
- Check whether the motor and electric equipment are dry or not, the insulation is well or not.
- Power switch must be installed in safe place ( chart 2-18 set 1 red revolve botton )
- When it used three-phase voltage, overcurrent protection are equipped. Each attribute should be adjusted properly. (see as Fig 1 )

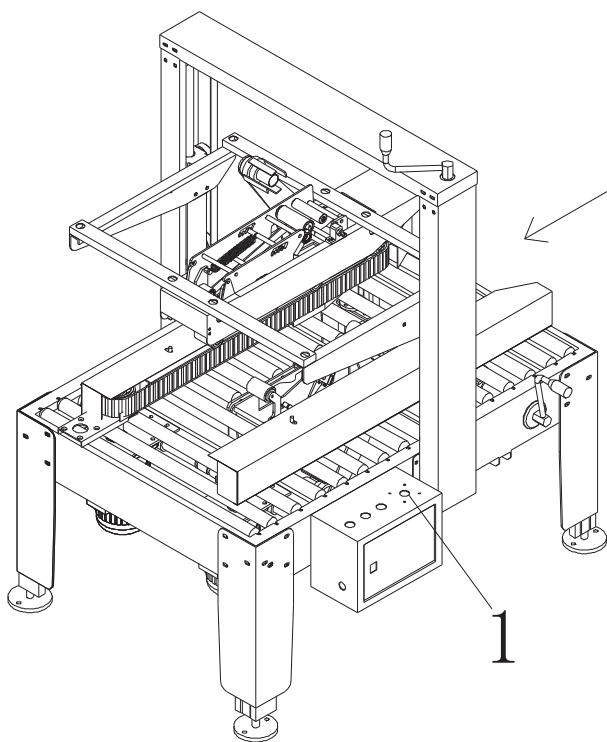

Chart 2-18

### Single-phase machine

<b>Voltage(V)</b>	220	220	240	110	100
<b>Frequency (Hz)</b>	50	60	50	60	50/60
<b>Electric current(A)</b>	2.5	2.5	2.5	6.0	5.0

### Three phase machine

<b>Voltage(V)</b>	220	400	240	260	415	440	200
<b>Frequency(Hz)</b>	50	50	50	50	50	50	50/60
<b>Electric current (A)</b>	1.6	0.9	1.6	1.6	0.9	0.9	1.6

FIG 1



## 12. Debugging:

- Switch on the power supply after 2-5 minutes' operation, check whether operation is normal.
- Shaking the handle of adjusting width by hand to assure if the movement of side impetus equipment is flexible.
- Shaking the handle of adjusting height by hand to assure if the movement of Upper band conveyer equipment is flexible.
- Check whether the belt is out of side.
- Adjust the degree of tightness of the belt.
- Check whether the flow of the inner adhesive tape of the cassette mechanism is smooth.

### Notice:

The machine can only use onboard plug, please do not remove the plug wires

- Put a machine into service, please click the start button.
- Check whether the girdle turn to the correct direction. (transmission direction of cartons), the transmission direction is point with the arrow in Chart 2-18. If use three phase machine, and the transmission direction is not correct, please exchange both ends of the plug.

## PART 3: SETTING

### 1. Pretreatment

Put the cartons which need sealed on the roller way, then install different conditions properly.

### 2. Install up plane head

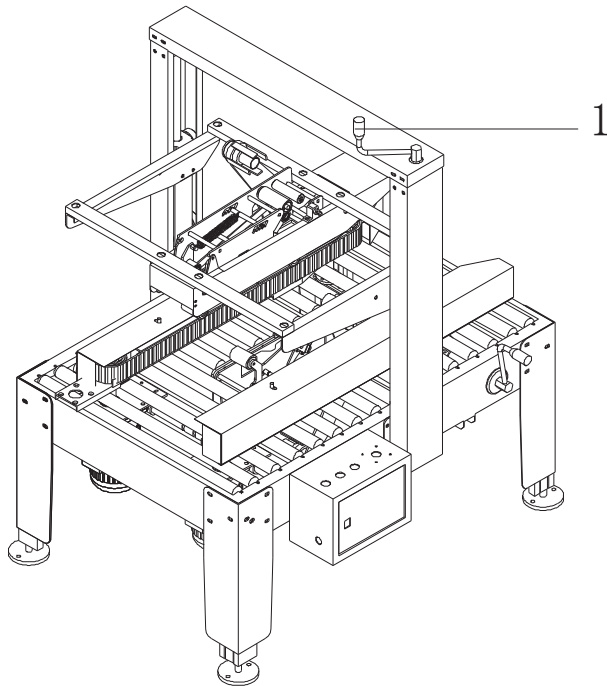

Chart 3-1

Put the carton into the machine, shown as Chart 3-1, install plane head by dint of the racker (Chart 3-1 seat 1), make the plane head moved down to the top edge of the carton.

### 3. Install cutout of the rallaway

Put the carton on specific location, agitating the handle(Chart 3-2 seat 1) until the belt touch the edge of the carton.

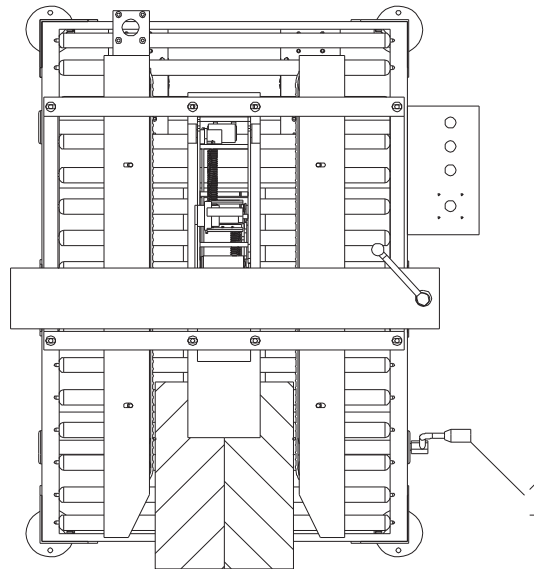

Chart 3-2

### 4. Install side wheel

Put the roller on the upside of the carton,then fixed (Chart 3-3)

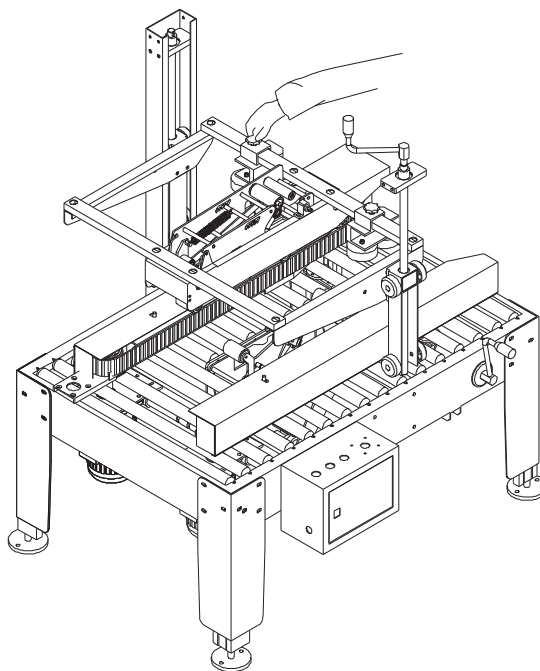

Chart 3-3

## 5. Cycle of operation

- Start the machine get by start botton.
- Manhandle the carton, when the carton get to the place of side power plant,the belt of side power plant driving the carton along.
- Upside and underside of Sealed body are pressing and sticking with up and down nip rollers,come into being autoboxing
- After the refquier of feeling acrton is contened,the blade auto shut the adhesive tape down.
- Keep the machine automatic working, the process to finish sealing a carton is a cycle of operation.

### Notice:

The carton has to lie in the middle of the machine,meanwhile,maintaining the space between.

## 6. Warning of corrective maintenance

### Notice:

When the machine is broken down,please ask the professional to overhaul,the one have to know on the electric motor and machinery. Befor maintaining,must be sure there ia enough space around the machine in order that the professional can shy away from hurt in maintaining.

## 7. Steps of maintenance:

- Stop the machine.
- Cut off the power supply.
- Take down the plane head.
- Take other machinery parts of the machine down.
- Take off the machine from equipments.
- Prepare for transporting the machine,fastening moving parts.

### **If the machine scrap ,please go ahead according to following process:**

- Take the protective devices down.
- Classify the parts on different materials. (metal、plastics、rubber etc.) , then go ahead the garbage classification for it.

## 8. Frequent trouble and troubleshooting:

### 8.1 The adhesive tape deviates the center of the box body:

adjust the position of the adhesive tape.(Chart 3-4)

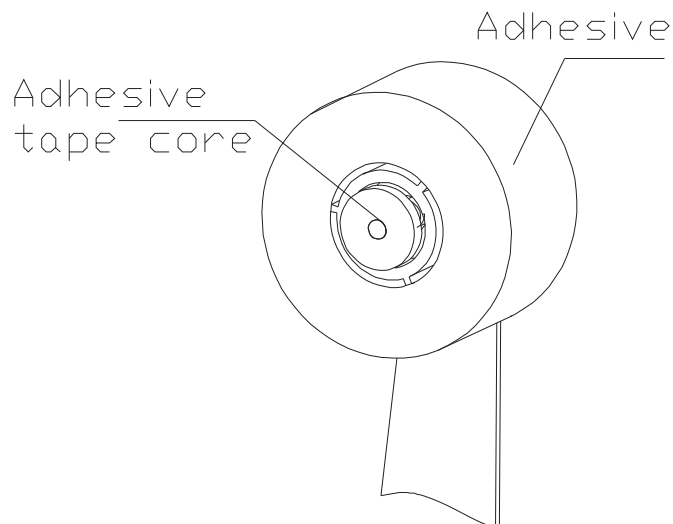

Chart 3-4

### 8.2 The adhesive tape can not be cut off:

the blade is too high and easy to scrape the carton.

The blade is too low easily led to that the adhesive tape can not be cut off. (Chart 3-5)

### 8.3 The adhesive tape can not press through (the carton has not press firmly) :

the quality of the adhesive tape is not so good or oneway rubber wheel is wrong (Chart 3-5)

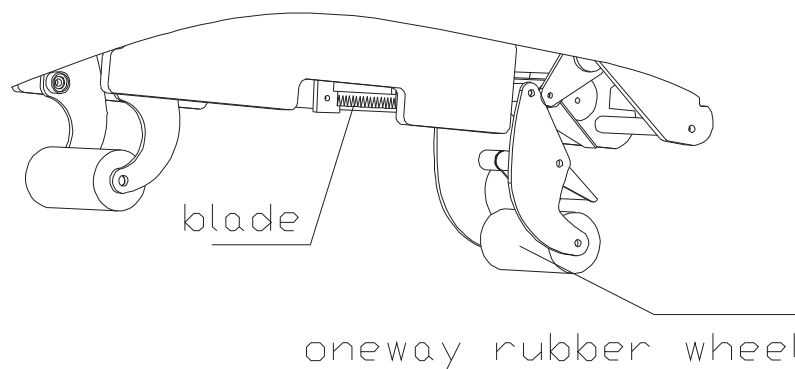
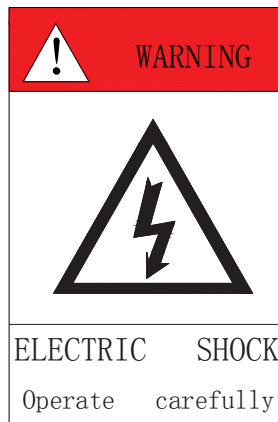

Chart 3-5

9. Warning mark

1. Electric shock, operate carefully!



2. Rolling, keep hands away!

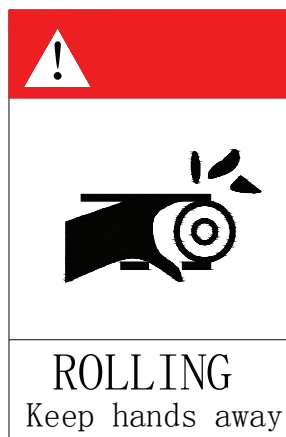

3. Dangerous, Do not touch!



## 10. Catalogue of possible trouble

- 10.1. The machine can not start up.
- 10.2. The machine alarming.
- 10.3. The girde can not work.
- 10.4. Automatic circulation is broken.

### 10.1. Trouble description: The machine can not start up.

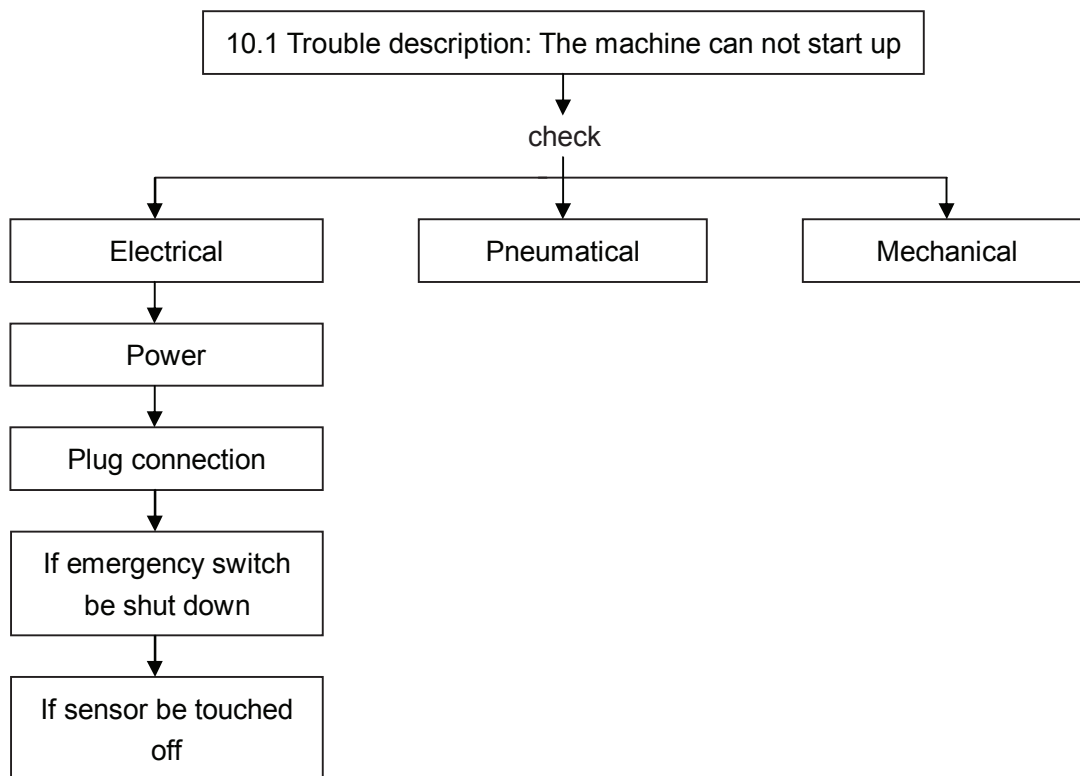

**10.2. Trouble description: The machine alarming.**

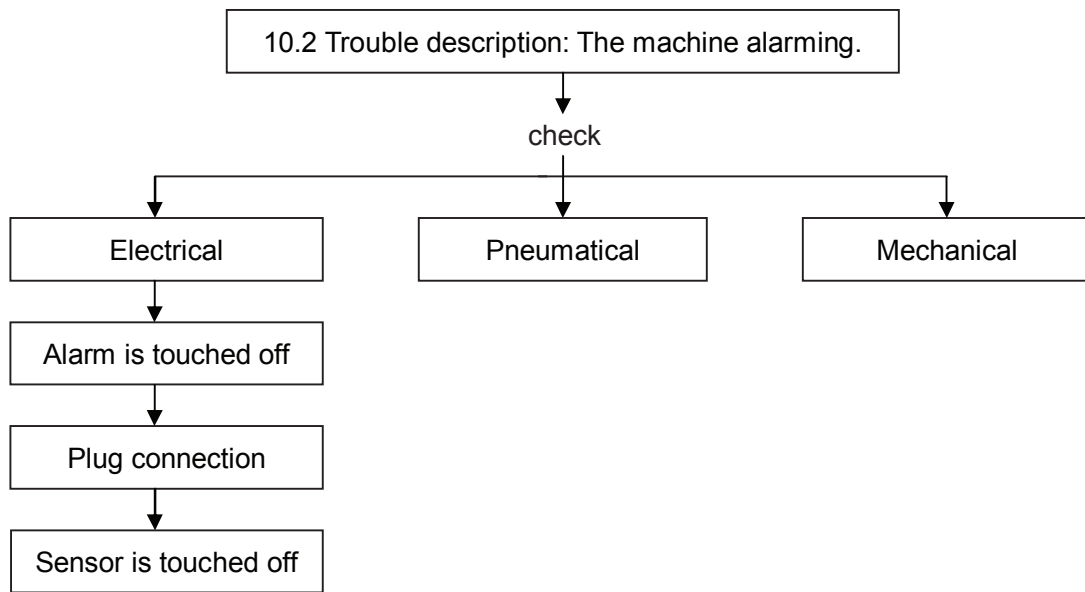



**10.3. Trouble description: The girde can not work.**

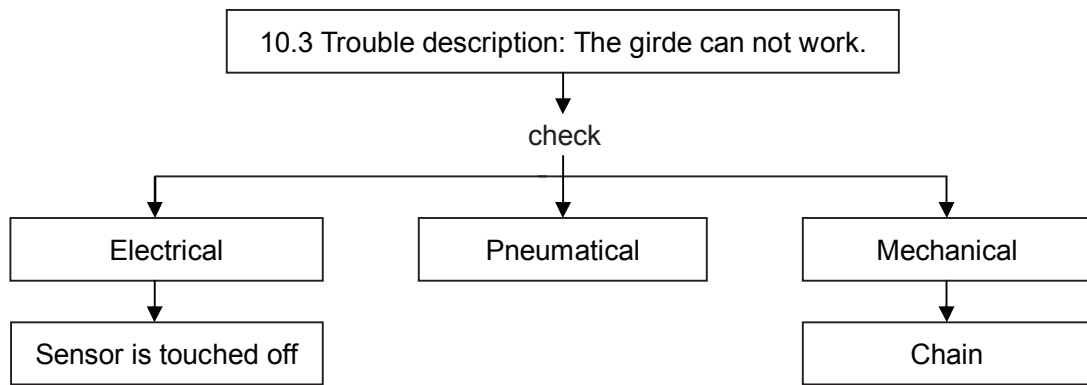

#### 10.4. Trouble description: Automatic circulation is broken

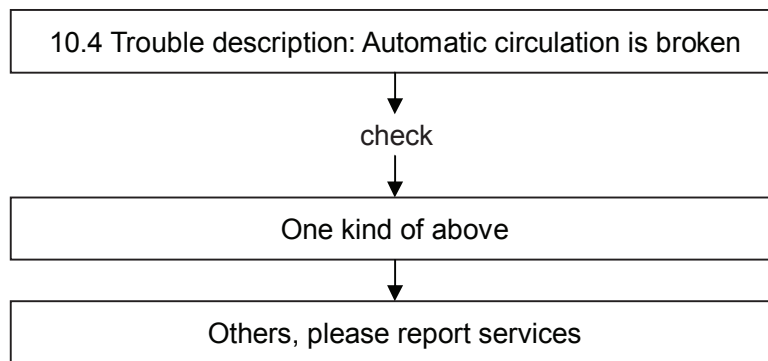

## PART 4: SERVICE

### 1. Daily maintenance

It is favourable for the machine if screws require periodic inspection that to insure well operatin. Moreover, working speed of the carton sealer is fast, in the place of big amount of work, every machine should works 16 hours a day. Thus keep parts in good lubrication usual. Must lubricate major parts regularly which are not listed in the manual to make the machine long service life.

### 2. Replace rollaway girde

After long term usage, rollaway girde maybe broken. If you want to replace it, please refer to the process as follows:

- Srew off 4 screws ( Chart 4-1 post 1 ) , take down the protective cover of girde.
- Ease grade the adjuster bolt ( Chart 4-1 post 2 ) , up to the girde is flexible
- Replace the girde.
- Manual rotate girde, meanwhile ,lead the girde in place
- Screw down the adjuster bolt ( Chart 4-1 post 2 ) .
- Correct tensity determined through pulling the middle of Rollaway lightly ( Chart 4-2 ) , Girdle swell needed about 20mm, with the screwdrive r to adjust adjuster bolt ( Chart 4-1 post 2, right to screw down, left yo relax ) .
- Cover the protective cover ,set screws.

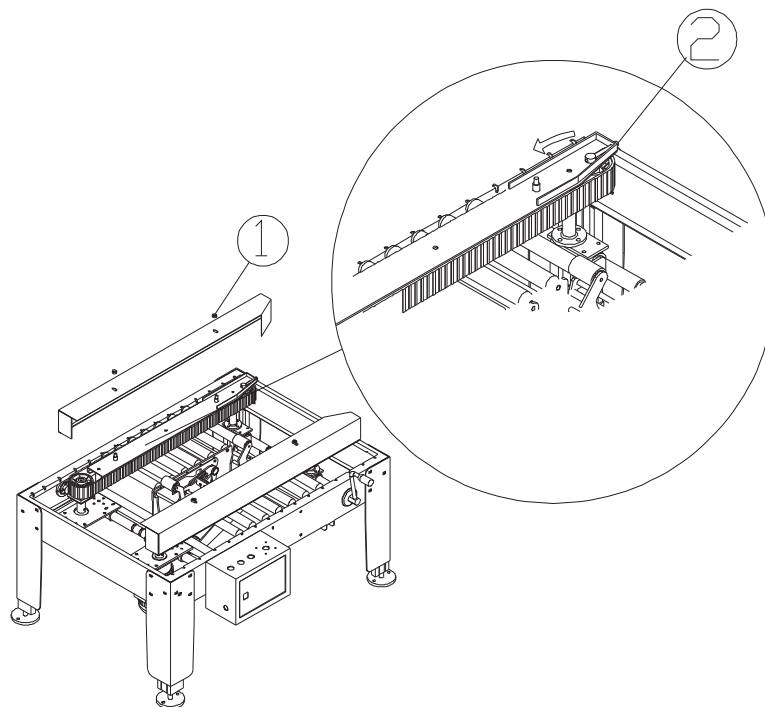

Chart 4-1

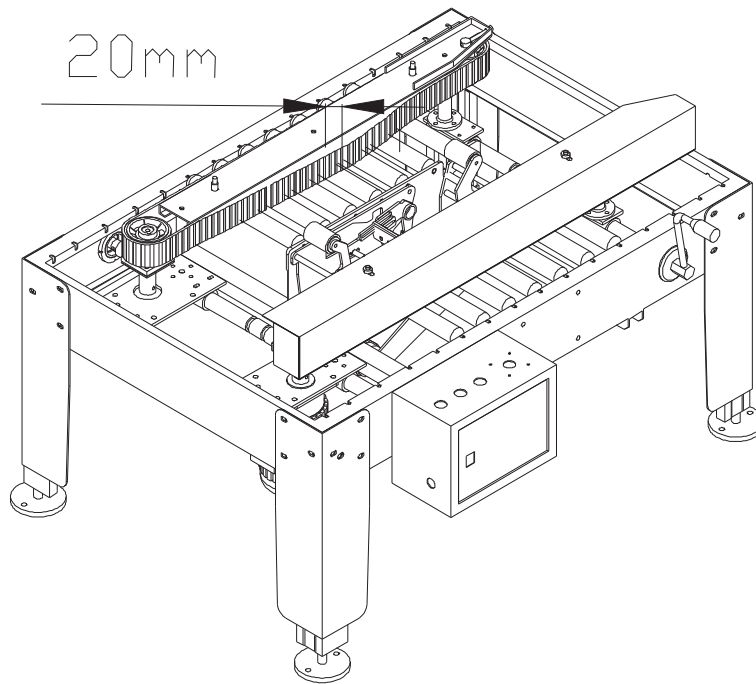

Chart 4-2

### 3. Components Items repaired or changed by operator

No.	Change component name	Code No.
1	Side power belt	1867mm
2	Tension spring shaft of knife carrier	FJ-00-01
3	Knife rest down tension spring	FJ-H-05
4	Blade shelf defending torsion spring	FJ-H-01
5	blade	
6	Tape pressing plate torsion spring	FJ-H-03

### 4. Routine check and clean

- Must check all screws loosen or not of every part of the machine.
- Must lubricate major parts regularly.
- Remain the machine surface clean.
- Clean up foreign bodies on the blade every day.
- Spread lubricating grease on the blade if the machine is not be used in a long time.

## PART 5: CHART AND LIST FOR MAIN PARTS

### 1. Machine frame component

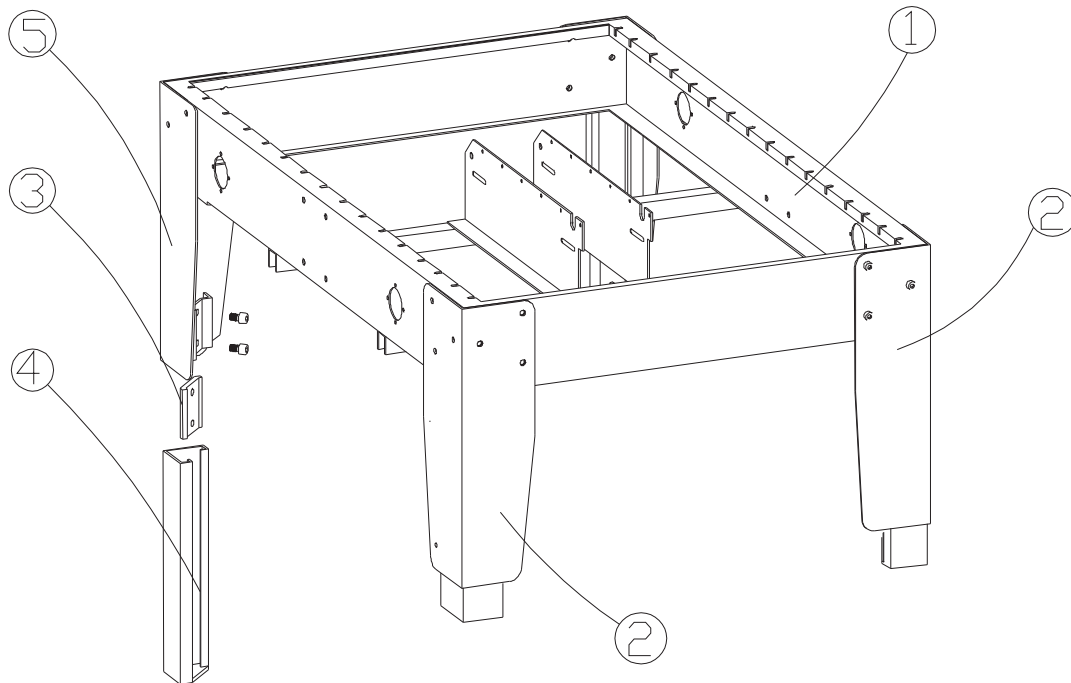

#### detailed parts list

no.	name	code no.	qty	remark
1	Machine frame	FJ-1AW-1	1	
2	Front machine feet	FJ-1AW-8	2	
3	Connection plate	FJ-1AW-100	4	
4	Extension tube	FJ-1AW-10	4	
5	Behind machine feet	FJ-1AW-9	2	

## 2. Upright post component (lifting gear)

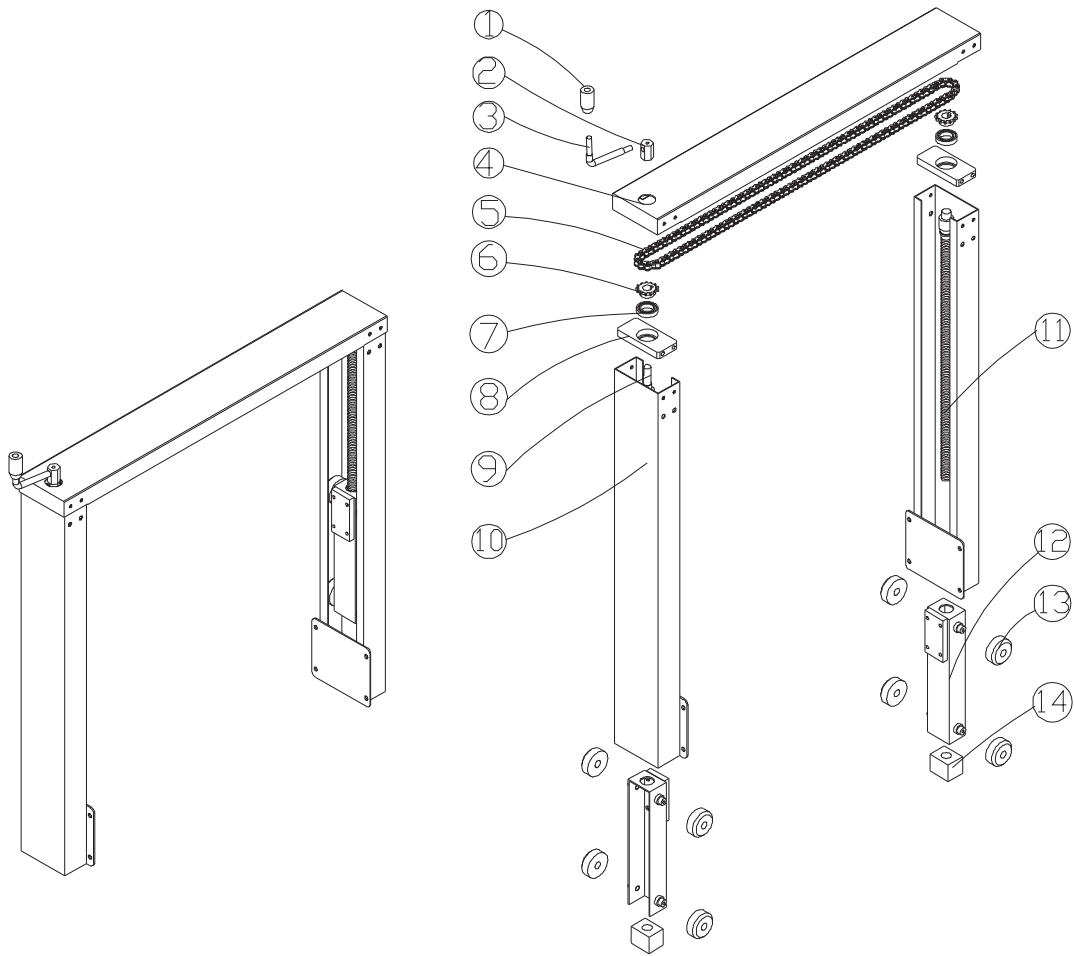

**detailed parts list**

<b>no.</b>	<b>name</b>	<b>code no.</b>	<b>qty</b>	<b>remark</b>
1	Handle	FJ-1AW-103	1	
2	Bending pole	FJ-1AW-101	1	
3	Helve	FJ-1AW-106	1	
4	Beam	FJ-1AW-38	1	
5	Chain	06B-1X186L	1	06B
6	Chain wheel	FJ-1AW-107	2	
7	Bearing	6004-2Z	2	
8	Upper supporting board	FJ-1AW-75	4	
9	Lift leading screw II	FJ-1AW-77	1	
10	Upright post body	FJ-1AW-26	2	
11	Lift leading screw	FJ-1AW-78	1	
12	Lift body	FJ-1AW-13	2	
13	Idler wheel	FJ-1A-105	8	
14	Nut	FJ-1A-106	2	

### 3. Roller combination

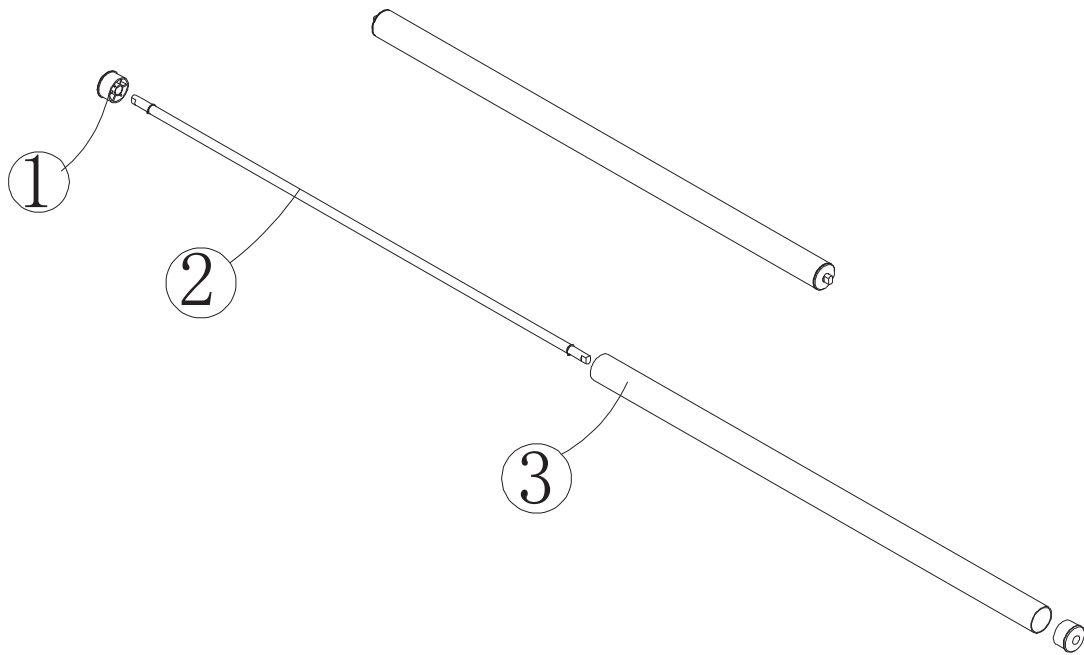

#### detailed parts list

no.	name	code no.	qty	remark
1	inside and outside end plate	φ32 roller	2	Match with 6001 bearing
2	Long shaft	FJ-1AW-57	1	
	Short shaft	FJ-1AW-55	1	
3	Roller	FJ-1AW-56	1	



#### 4. Side power plant

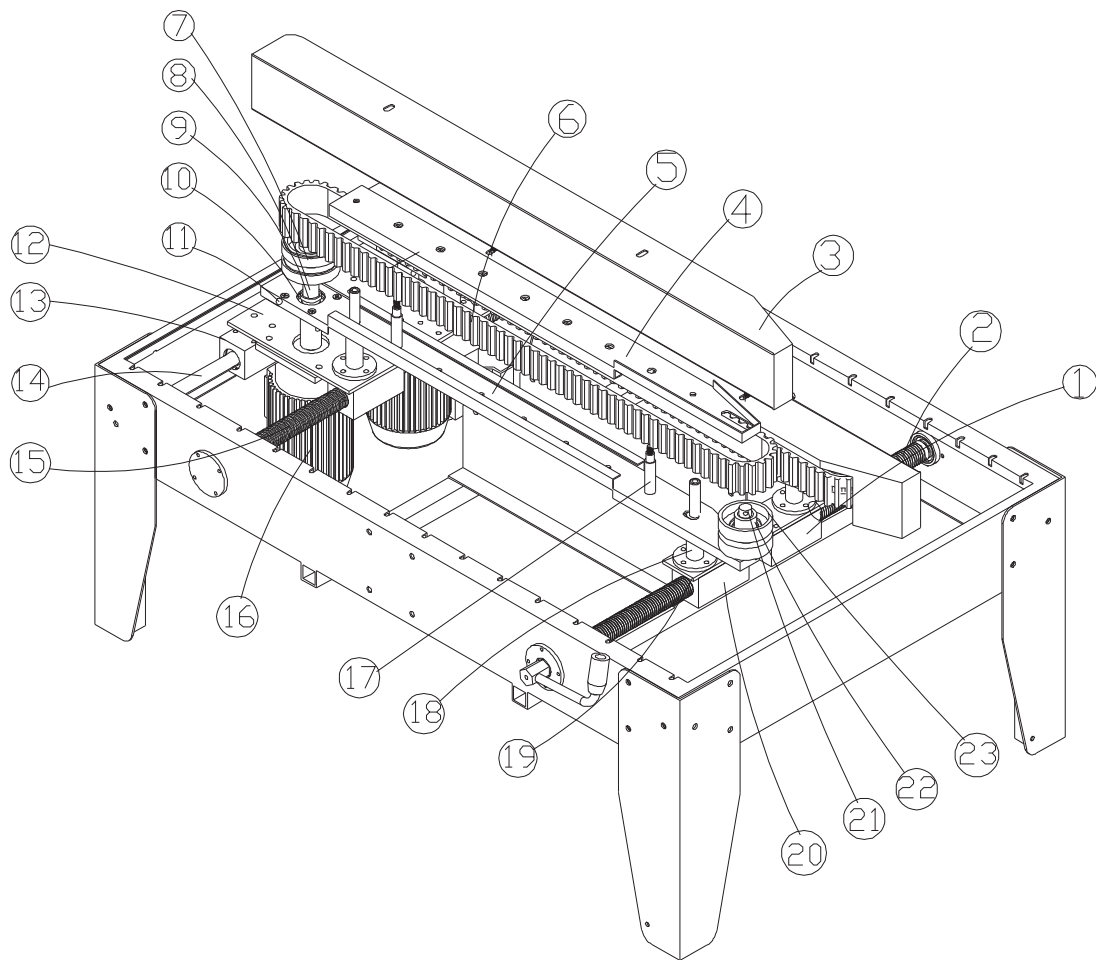

### detailed parts list

no.	name	code no.	qty	remark
1	Right nut Seat	FJ-1AW-98	2	
2	Left and right leading screw ( II )	FJ-1AW-53	1	
3	Cover plate	FJ-1AW-43	1	each
4	Upper plate of side power	FJ-1AW-50	2	
5	Lower plate of side power	FJ-1AW-46	2	
6	Belt	1867mm	2	
7	Driving wheel	FJ-1AW-80	2	
8	Main driving wheel	FJ-1AW-70	2	
9	Spacer bush of driving wheel	FJ-1AW-99	2	
10	Bearing	6005-2Z	2	
11	Shaft block	FJ-1AW-82	2	
12	Install panel	FJ-1AW-84	2	
13	Linear bearing base	FJ-1AW-114	2	
14	Guide column	FJ-1AW-52	1	
15	Left and right leading screw ( I )	FJ-1AW-54	1	
16	Motor	CV200/20Z G1、G2	Each1	
17	Fulcrum	FJ-1AW-63	4	
18	Connection pole	FJ-1AW-67	4	
19	Orientation plate	FJ-1AW-85	2	
20	Left -rotate nut	FJ-1AW-97	2	
21	Tensioning shaft	FJ-1AW-64	2	
22	Tension sheel sleeve	FJ-1AW-66	4	
23	Wheel	FJ-1AW-81	2	Enhance PA
24	Chain wheel	FJ-1AW-88	2	

## 5. Plane head

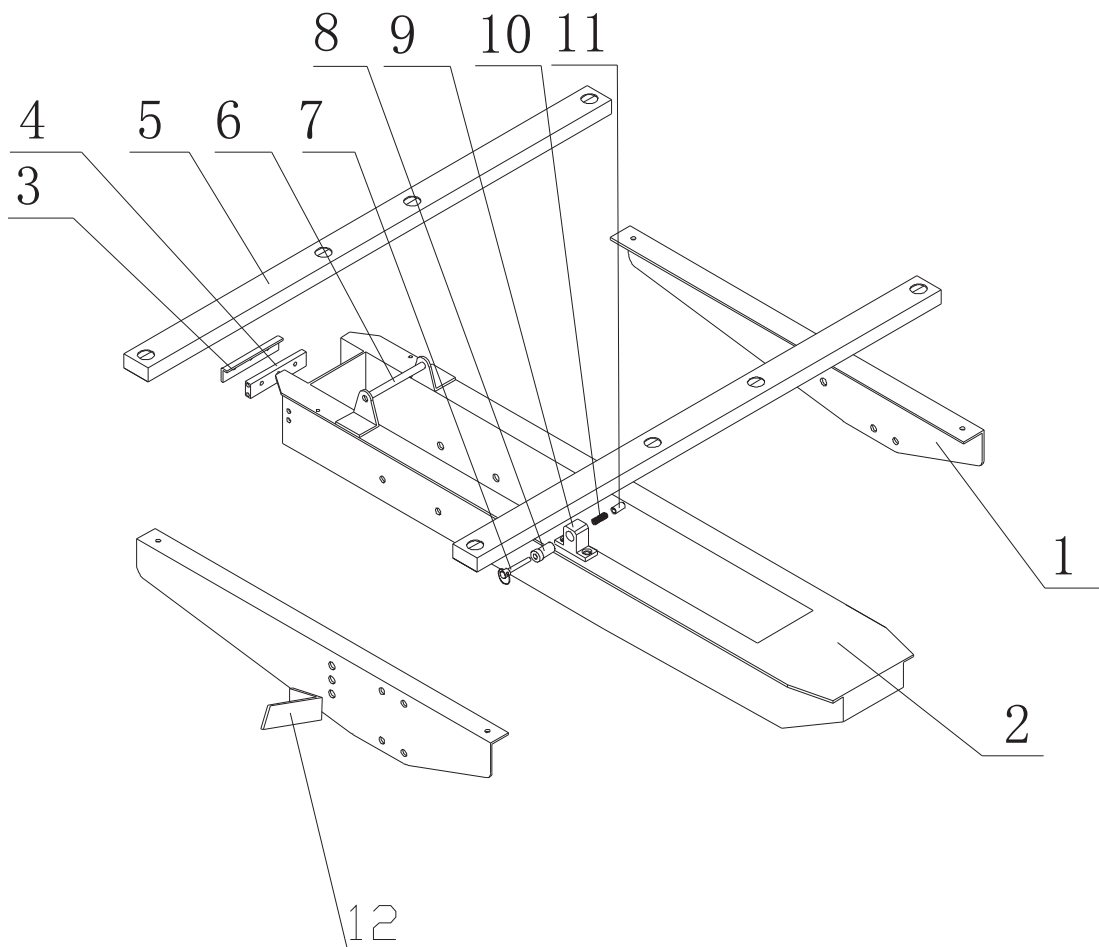
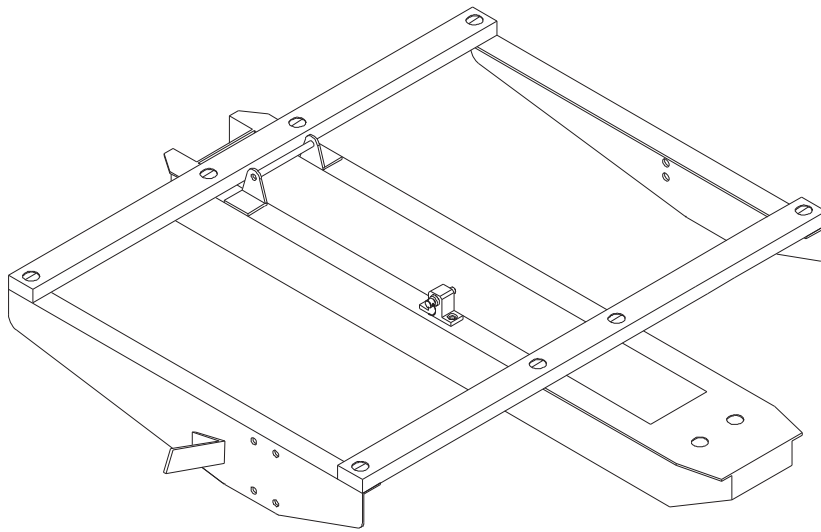

**detailed parts list**

<b>no.</b>	<b>name</b>	<b>code no.</b>	<b>qty</b>	<b>remark</b>
1	Support plate	FJ-1AW-35	2	
2	Plane head frame	FJ-1AW-29	1	
3	Pressure pad	FJ-1AW-59	1	
4	Brush carrier	FJ-1AW-58	1	
5	Footbridge	FJ-1AW-39	2	
6	Supporting axle	FJ-1AW-61	1	
7	Pull rod	FJ-1AW-111	1	
8	Spring seat	FJ-1AW-109	1	
9	Fixed block	FJ-1AW-42	1	
10	Lock pressure spring	FJ-1AW-105	1	
11	Rocker die	FJ-1AW-110	1	
12	Ruler	FJ-1AW-41	1	

## 6. Holding box equipment

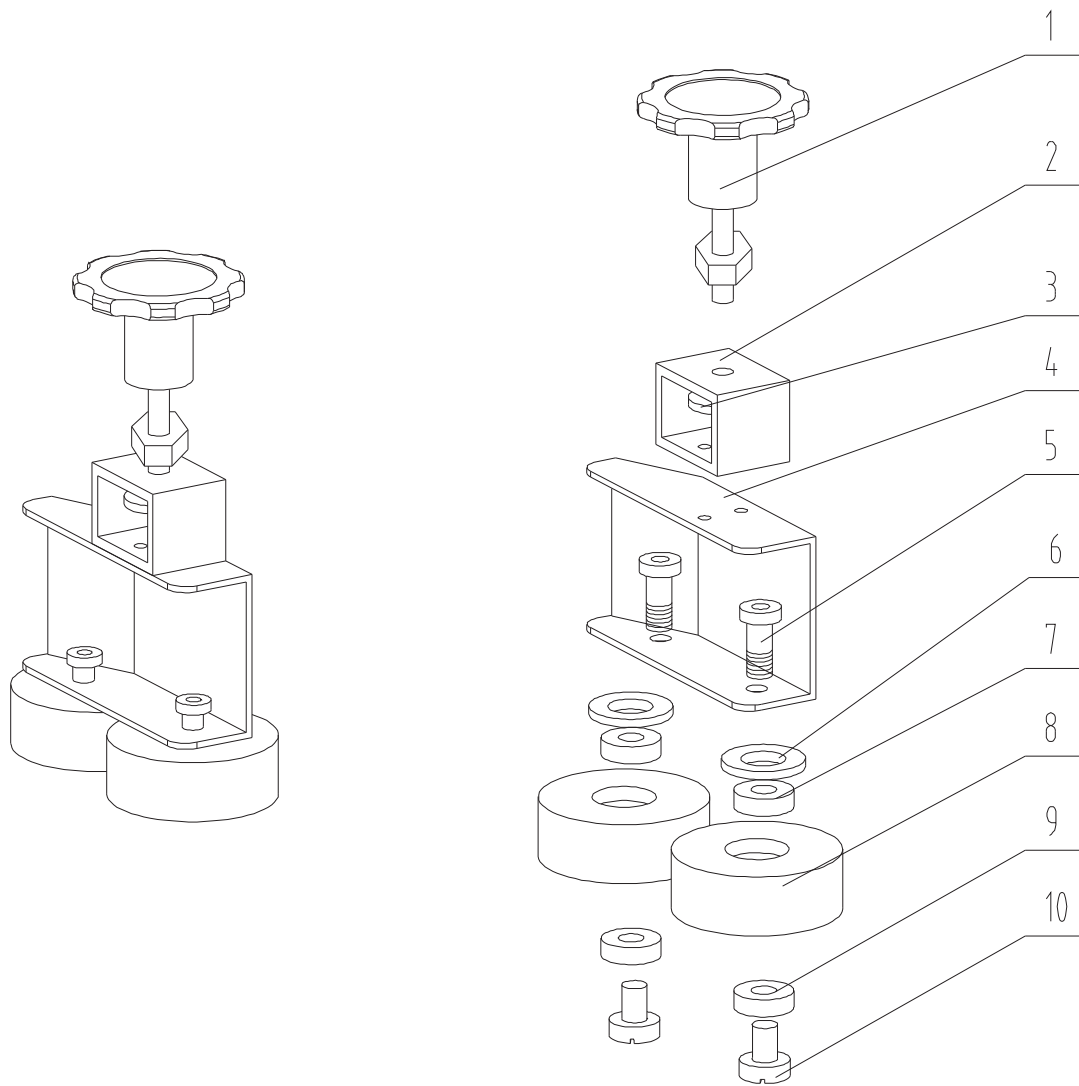

**detailed parts list**

<b>no.</b>	<b>name</b>	<b>code no.</b>	<b>qty</b>	<b>remark</b>
1	Handwheel	FJ-1AW-102	1	
2	Holding box rivet rack	FJ-1AW-36	1	
3	Backing board	FJ-1AW-113	1	
4	Holding box frame	FJ-1AW-37	1	
5	Contact roller	M10X20mm	2	
6	Washer	Ø10	2	
7	Spacer bush	FJ-1A-122	2	
8	Roller	FJ-1AW-90	2	
9	Bearing	6023Z	2	
10	Shaft	FJ-1AW-104	2	

## 7. Cassette mechanism

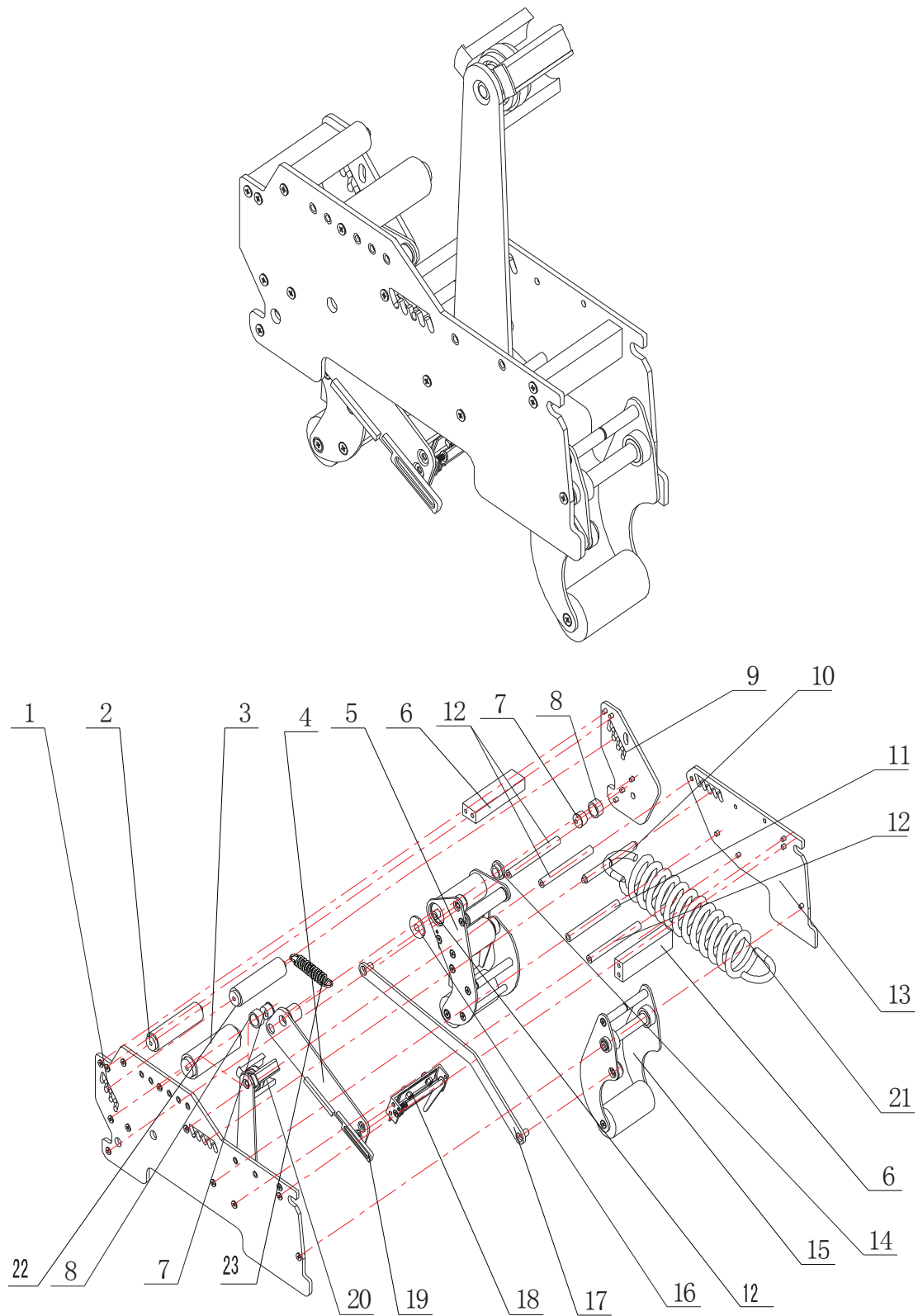

### detailed parts list

no.	name	code no.	qty	remark
1	Side plate	FJ-01-17	1	
2	Guide pulley combination		1	See 7.4
3	One way roller combination		1	See 7.3
4	Blade carrier	FJ-01-21	1	
5	Front claw combination		1	See 7.1
6	Square pole(1)	FJ-01-00	2	
7	Shaft	FJ-00-12	2	
8	Cushion collar	FJ-40-00	2	
9	Platelet	FJ-01-02	1	
10	Large shaft of tension spring	FJ-00-02	1	
11	Supporting axle	FJ-00-07	1	
12	Main fulcrum	FJ-00-06	4	
13	Set square	FJ-01-16	1	
14	Spacer bush of front claw	FJ-02-09	1	
15	Back roller side plate combination		1	See 7.2
16	Sheet brass	FJ-02-04	1	
17	Connecting rod	FJ-01-15	1	
18	Knift back plate combination		1	See 7.5
19	Knife leveling piece	FJ-01-01	1	
20	Adhesive tape wheel combination		1	See 7.6
21	Down tension spring of movement	FJ-H-07	1	
22	Knife tension spring axle	FJ-00-01	1	
23	Down tension spring of knift rest	FJ-H-05	1	



## 7.1. Front claw combination

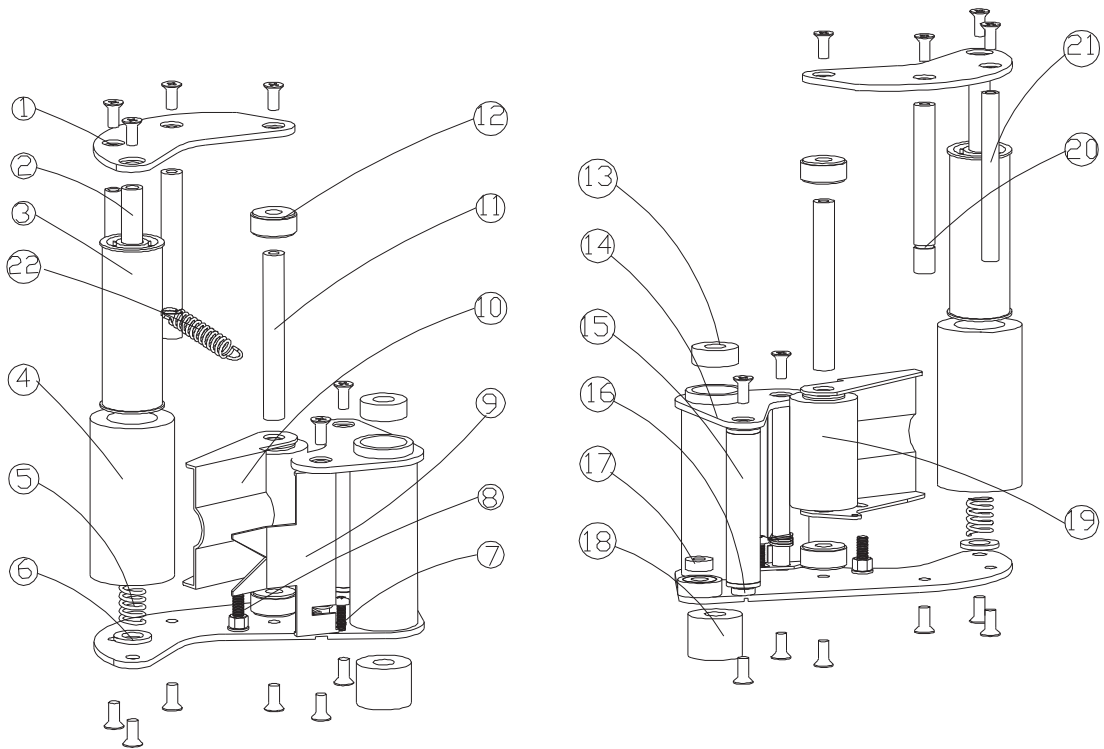
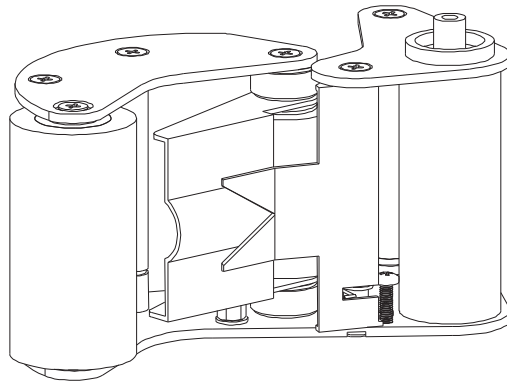

### detailed parts list

no.	name	code no.	qty	remark
1	Synapticulum	FJ-01-09	1	
2	Front and back roller shaft	FJ-00-10	1	
3	Onr way roller shaft	FJ-E-38-01	1	
4	Front rubber roller wheel	FJ-E-41-01	1	
5	Press spring of front roller wheel	FJ-H-02	1	
6	Washer of front roller wheel	FJ-04-06	1	
7	Cross flat trench screw	M4x12	1	
8	Cross flat head screw	M5x15	1	
9	Press tape board combination		1	See 7.8
10	Guide tape board combination	FJ-01-08	1	See 7.9
11	fulcrum of front claw	FJ-00-09	1	
12	spacer of guide tape board	FJ-02-02	2	
13	Bearing	6900 (1080900)	1	
14	Front claw	FJ-50-00	1	
15	Guide tape wheel combination		1	See 7.7
16	knurlingspacer bush of guide tape wheel	FJ-02-11	1	
17	Bearing	688Z (208088)	1	
18	Bearing	HK2020	1	
19	Roller wheel of Guide tape board	FJ-02-10	1	
20	Tehsion spring shaft	FJ-00-11	1	
21	Fulcrum of front claw	FJ-00-09	1	
22	Tension spring of guide tape board	FJ-H-00	1	

## 7.2. Back roller side plate combination

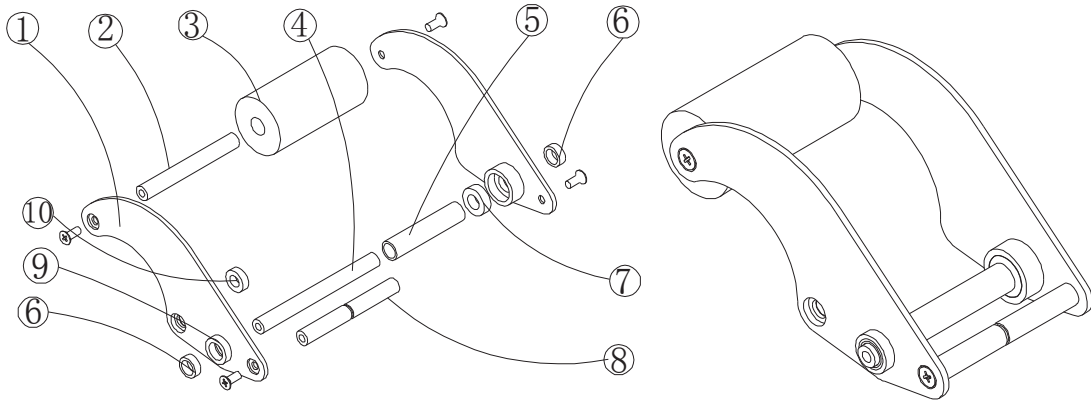

### detailed parts list

no.	name	code no.	qty	remark
1	Back synapticulum	FJ-01-13	each 1	
2	Front and back roller shaft	FJ-00-10	1	
3	Back rubber roller wheel	FJ-40-03	1	
4	Main fulcrum	FJ-00-06	1	
5	Axle sleeve of back claw	FJ-02-05	1	
6	Back locating ring	FJ-02-06	2	
7	Bearing	6800Z (26800)	2	
8	Tension spring shaft of back claw	FJ-00-05	1	
9	Washer of back claw	FJ-02-00	1	
10	Bearing	688Z (208088)	1	

### 7.3. Reicnlbation roller combination

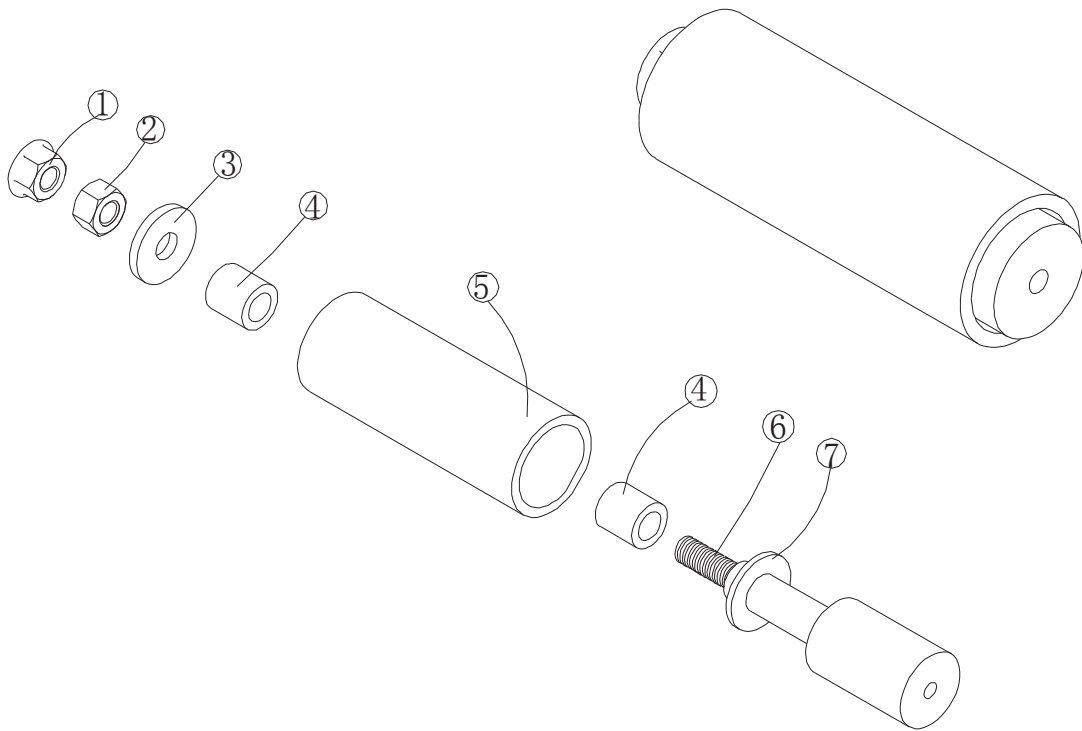

#### detailed parts list

no.	name	code no.	qty	remark
1	Locknut	M8	1	
2	Nut	M8	1	
3	Washer of one way wheel	FJ-02-03	1	φ8
4	Bearing	HF1216	2	
5	Reicnlbation roller	FJ02-00-03	1	
6	Shaft of one way wheel	FJ-00-04	1	
7	Speaser of one way wheel	FJ-02-01	1	

#### 7.4. Guide pulley combination

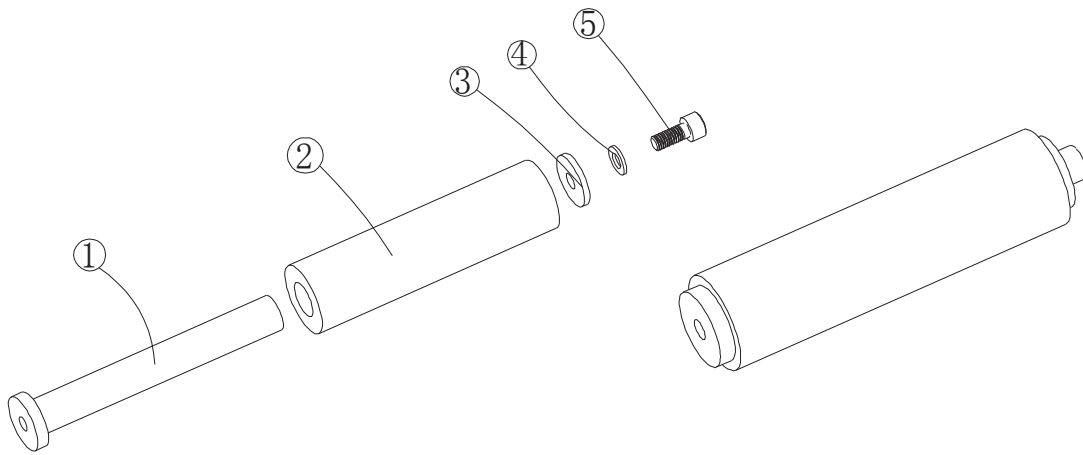

#### detailed parts list

no.	name	code no.	qty	remark
1	Guide pulley shaft	FJ-00-18	1	
2	Axle sleeve	FJ-E-37	1	
3	Big plain washer	φ5	1	
4	Flip washer	φ5	1	
5	hexagonal socket screw	M5X12	1	

## 7.5. knife back plate combination

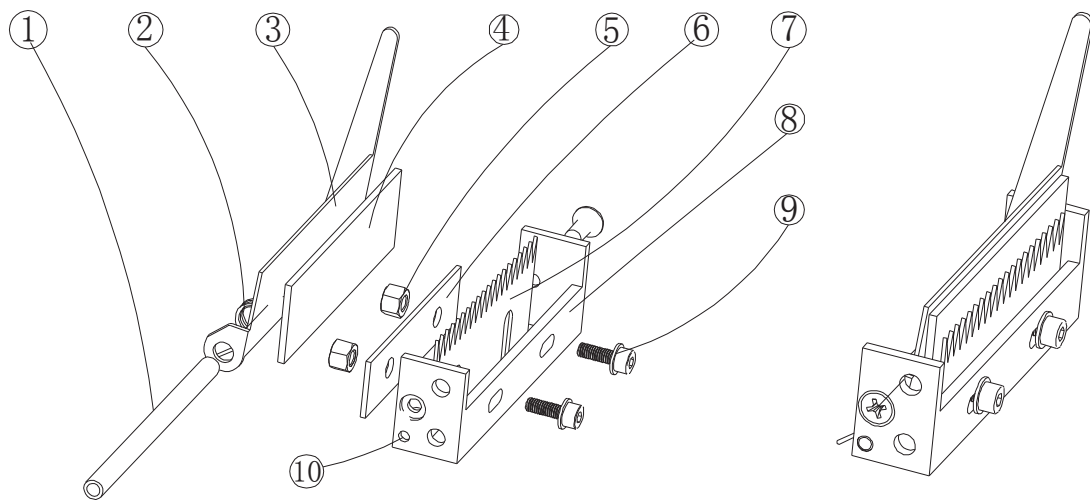

### detailed parts list

no.	name	code no.	qty	remark
1	Shaft of knife back plate	FJ-00-00	1	
2	Torsion spring of knife back plate	FJ-H-01	1	
3	Protecting blade carrier	FJ-01-06	1	
4	Sponges		1	
5	Nut	M4	1	
6	Knife board	FJ-40-04	1	
7	Blade		1	
8	Blade carrier block	FJ-01-07	1	
9	Hexagonal socket screw	M4x16	2	
10	Cross flat trough screw	M4x12	1	

## 7.6. Adhesive tape wheel combination

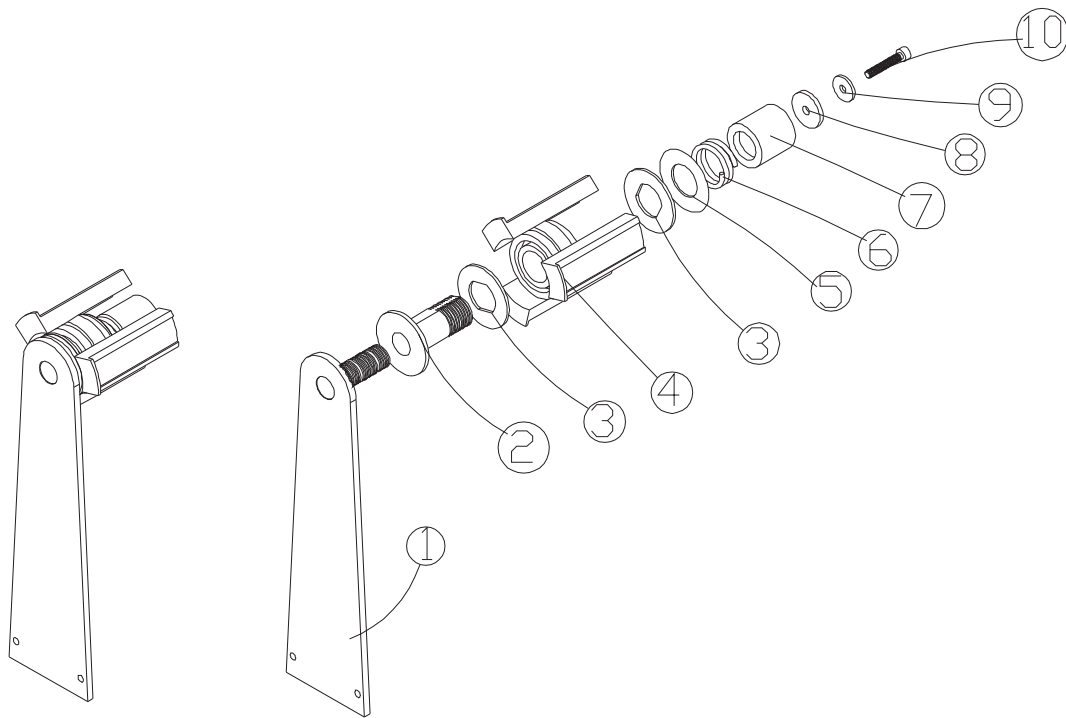

### detailed parts list

no.	name	code no.	qty	remark
1	Tape frame	FJ-05-01	1	
2	Axle sleeve of Adhesive tape wheel	FJ-02-12	1	
3	Antiskid slice	FJ-50-01	2	
4	Tape wheel	FJ-E-40-01	1	
5	Packing washer	FJ-05-02	1	
6	Pressure spring	FJ-H-08	1	
7	Hand nut	FJ-00-14	1	
8	Carrier ring	FJ-02-08	1	
9	Washer	φ5	1	
10	Lock nut	M5x40	1	

### 7.7. guide tape wheel combination

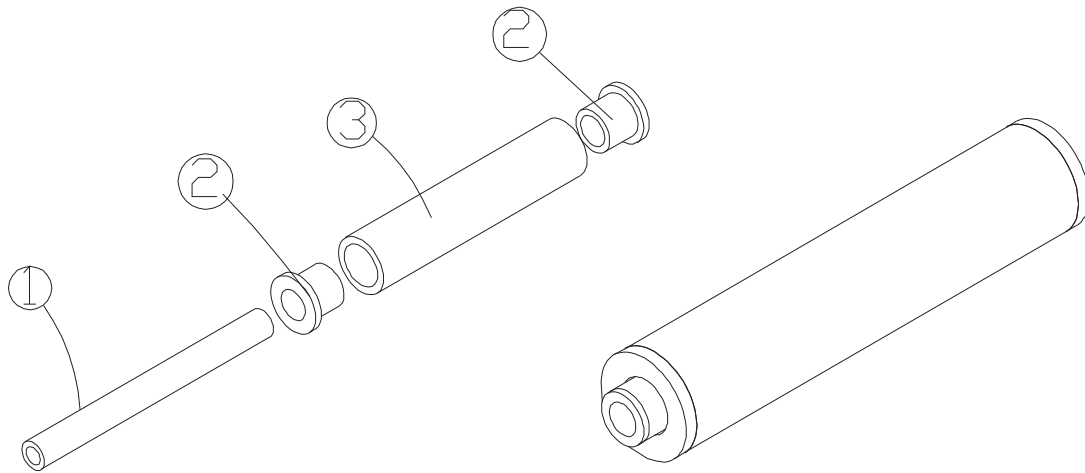

#### detailed parts list

no.	name	code no.	qty	remark
1	Fulcrum of front claw	FJ-00-09	1	
2	Knurling axle sleeve of guide tape wheel	FJ-02-14	2	
3	Guide tape wheel	FJ-02-13	1	



### 7.8. Press tape board combination

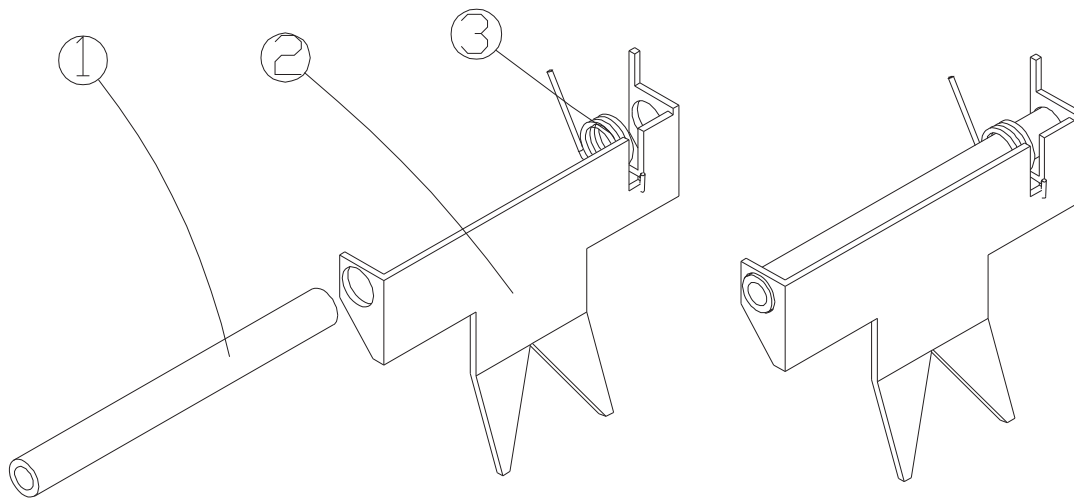

**detailed parts list**

no.	name	code no.	qty	remark
1	Fulcrum of front claw	FJ-00-09	1	
2	Press tape board	FJ-01-05	1	
3	Torsion spring of press tape board	FJ-H-03	1	

### 7.9. Guide tape board combination

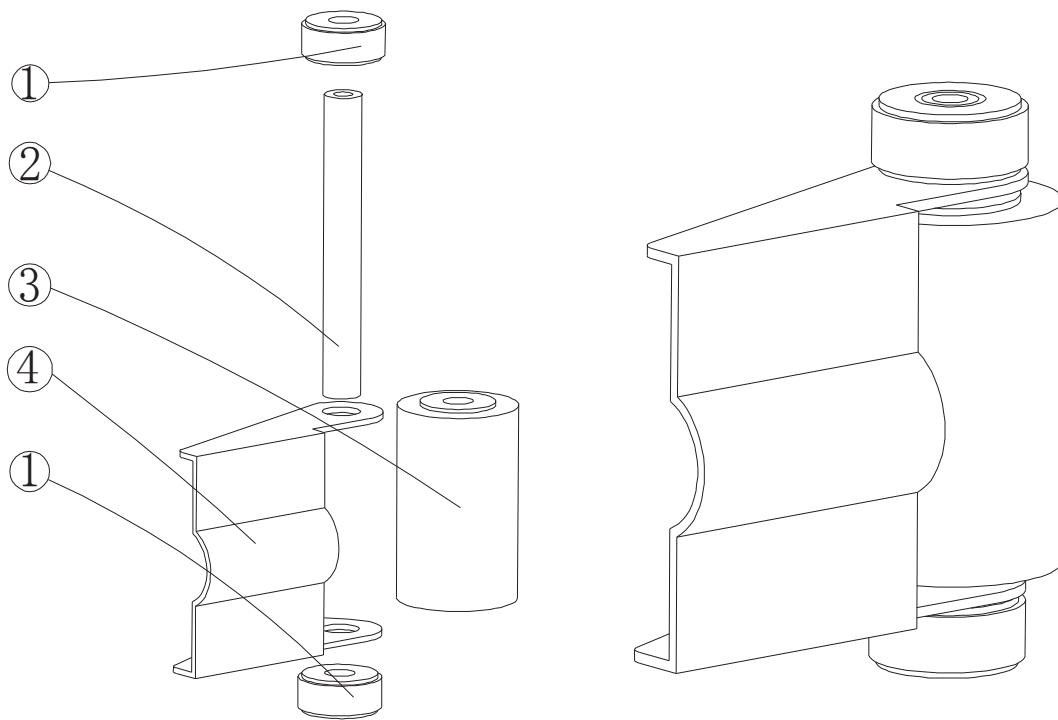

#### detailed parts list

no.	name	code no.	qty	remark
1	Spacer of Guide tape board	FJ-02-02	2	
2	Fulcrum of front claw	FJ-00-10	1	
3	Axle sleeve	FJ-02-10	1	
4	Guide tape board	FJ-01-08	1	

# PART 6: WIRING AND SCHEMATIC DIAGRAMS

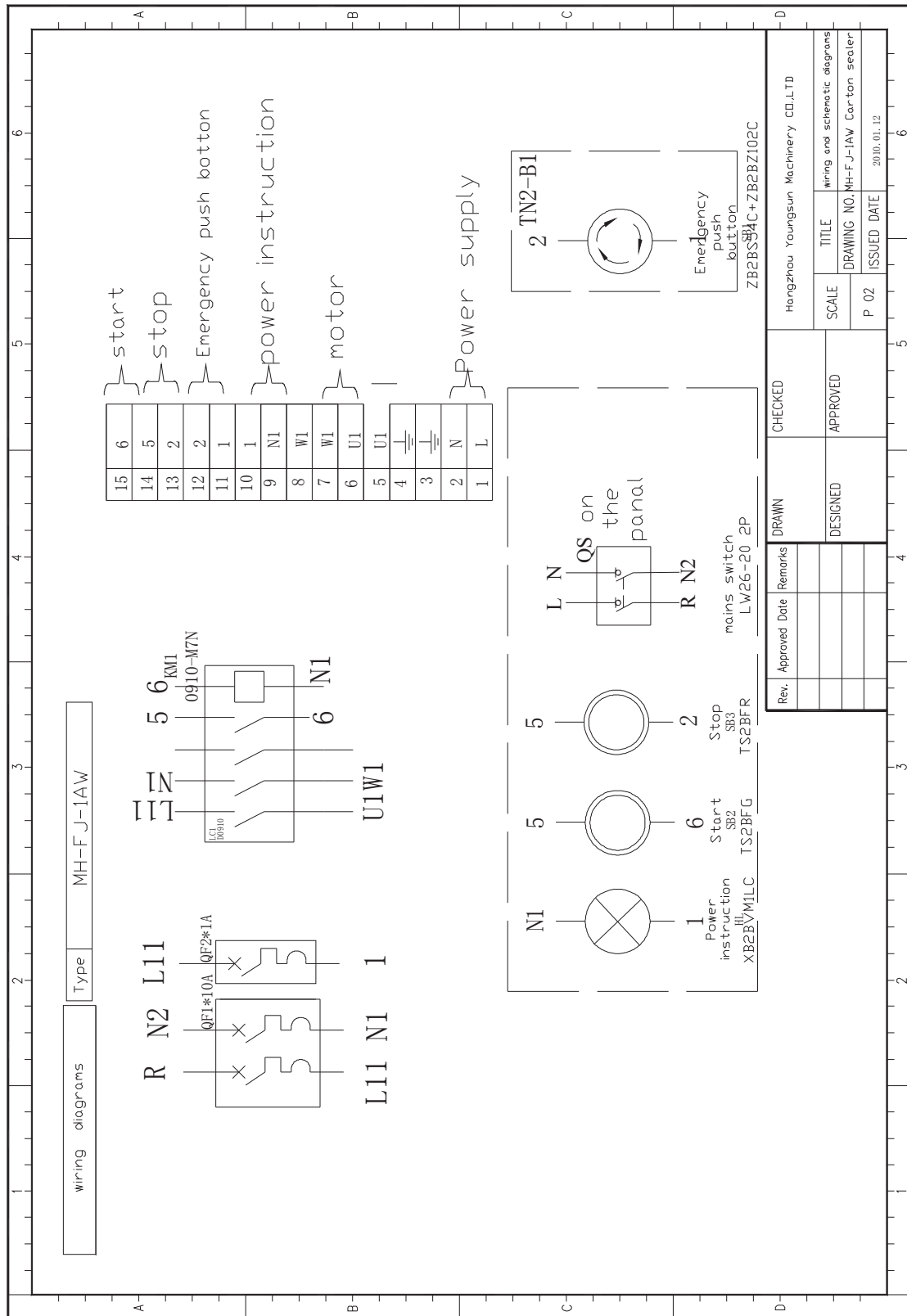

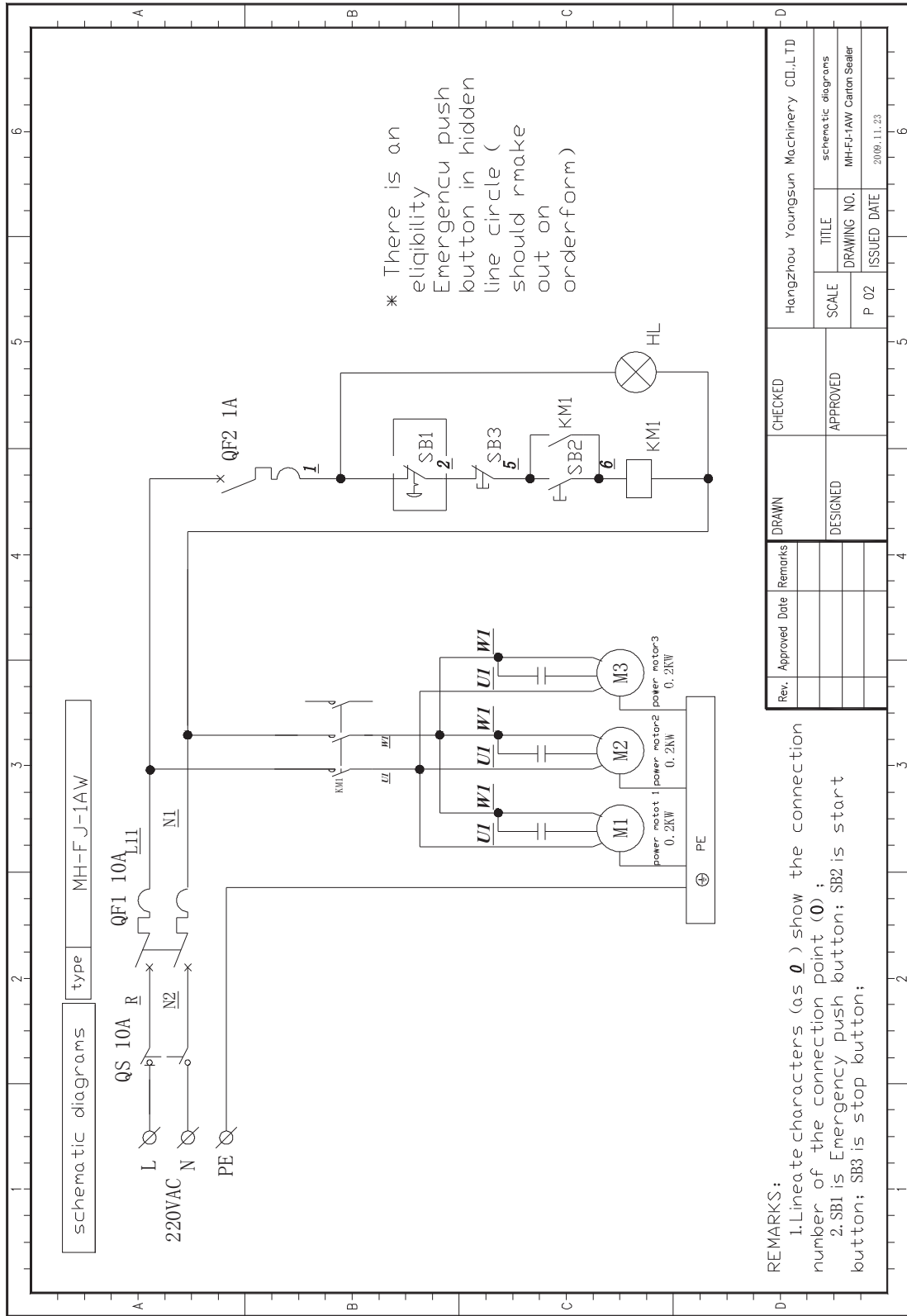

**REMARKS:**

1. Lineate characters (as **0** ) show the connection number of the connection point (**0**) ;
2. SB1 is Emergency push button; SB2 is start button; SB3 is stop button;

Rev.	Approved Date	Remarks	DRAWN	CHECKED	Hangzhou Youngsun Machinery CO.,LTD
			DESIGNED	APPROVED	SCALE
					TITLE
					DRAWING NO.
					ISSUED DATE
					P 02
					2009.11.23
					MH-FJ-1AW Carlton Sealer
					schematic diagrams

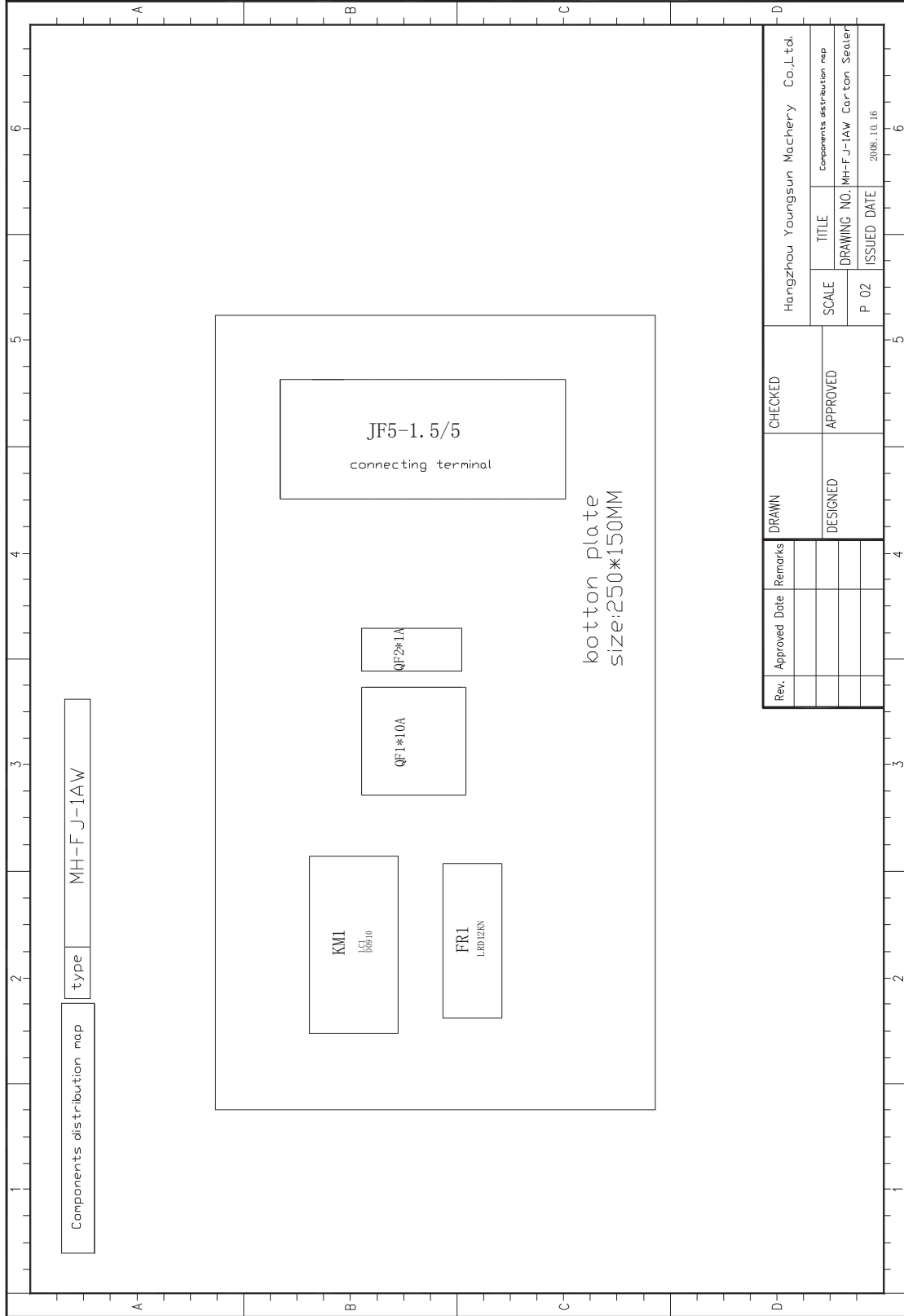

02 9452-3566

sales@getpacked.com.au